



**Quality Spares For
Triumph, BSA and Norton Motorcycles**



Click Here
To
Turn Page



**CATALOGUE
NO. 209W**



WWW.KLEMPFS.COM

Navigational Guide to our On-Line Catalogue

Welcome to our on-line catalogue. To assist you in using the features built into this catalogue, we are providing navigational aids.



About Clicking:

When instructed to "click," click once using your left mouse button.
When instructed to "right click", click once using the right mouse button.

Page Turning:

For next page: click anywhere on the right side of a page
For previous page: click anywhere on the left side of a page

Using the Index

Located in blue bar at top of page

Click on **Index**. Locate desired Index item(s) and click on a page number

Using Print (Quick Print)

Located in blue bar at top of page

Click **Print** and printing options appear

Make your printing selections

More Print Options

Right click anywhere on a page and select the **MenuBar** option. This will place a bar with additional functions at the top of your page. Once this has been done, you can access the following features to enhance your printing:

File/Print ActualSize: acts as the Quick Print option

File/Print FullSize: expands print to fit page --
select landscape for largest possible print

Using Close

Located in blue bar at top of page

Click **Close** to exit the catalogue

Right Click Menu

MenuBar: right click anywhere on a page for additional menu features

Go To: goes directly to catalogue page selected

TurnMode: modifies look of turning pages

Fly Speed: adjusts speed at which pages turn

Send Mail: sends catalogue to email address

Set Auto Turn: automatically turns pages

Background: covers unused area of the desktop with black background

Save As: saves catalogue with another filename of your choice

Exit: Closes the catalogue

Accessing our Website

Our website address (www.klempfs.com) appears at the bottom of each page. To access our website, click on the address.

INDEX

A

AIR FILTERS & ELEMENTS **24**
ALLEN CASE SCREW SETS **67**
ALTERNATOR & CHARGING SYSTEM **59, 60, 62**
AMAL CARBS & PARTS **7, 8, 9**
AMMETERS **57**

B

BATTERIES **62**
BEARINGS **11, 15, 34, 36, 37, 50, 52**
BOOKS & MANUALS **65, 66**
BRAKE HYDRAULICS & HOSES **25, 26**
BRAKE SHOES, PADS **10, 11**
BULBS **56, 57**

C

CABLES, CONTROL **23**
CABLES, SPEEDO & TACH **63**
CARBURETTORS **7, 8, 9**
CHAIN, PRIMARY DRIVE **21**
CHAIN, REAR DRIVE **22**
CHAIN GUARDS **43**
CHAINWHEELS **19**
CLUTCH PARTS **14, 19, 20**
CLUTCH PLATES **20**
COFFEE MUGS **65**
COILS **60**
CONDENSERS **60**
CONTACT POINTS **60**

E

ELECTRICAL PARTS, CHARGING **59, 60, 62**
ELECTRICAL PARTS, IGNITION **60**
ELECTRICAL PARTS, LIGHTING **56, 57, 58**
ENGINE BEARINGS **34, 36, 37**
EXHAUST FINNED CLIPS **36**
EXHAUST PIPES **38, 39**

F

FENDERS, FRONT & REAR **48**
FENDER STAYS **44, 49**
FOOTRESTS **42**
FOOTREST RUBBERS **42**
FORK BOOTS & WIPERS **52**
FORK PARTS **49, 50, 51, 52, 53, 54, 55**
FUEL TANK BADGES **45**
FUEL TANK HARDWARE **44, 45, 46**
FUEL TANK KNEE PADS **47**
FUEL TANK PETCOCKS **46**
FUSES & FUSE HOLDERS **57**

G

GASKETS & SETS **28, 29, 30**
GEARBOX PARTS **14, 15, 16, 17, 18**
GRIPS **47**

H

HANDLEBARS [47](#)
HANDRAILS [41](#)
HAYNES BOOKS & MANUALS [66](#)
HEAD GASKETS [30](#)
HEADLAMPS & PARTS [56, 57](#)
HEADLAMP BRACKETS [55](#)
HEAT SINK, ZENER DIODE [49](#)
HORNS [60](#)

K

KEY FOBS [65](#)
KICK START LEVERS & PARTS [14, 18](#)
KNEE PADS, FUEL TANK [47](#)

L

LAPEL BADGES [65](#)
LEVERS & PARTS [18, 22, 26](#)
LUCAS ELECTRICAL [56, 57, 58, 59, 60, 61](#)

M

MIRRORS [22](#)
MUFFLERS & CLAMPS [39](#)

O

OIL FILTERS & SCREENS [34, 37](#)
OIL PUMPS [34](#)
OWNERS MANUALS [65](#)

P

PETCOCKS [46](#)
PISTONS [35](#)
PRIMARY DRIVE PARTS [19, 20, 21](#)
PUSHRODS, ENGINE [36](#)

Q

QUARTZ HEADLAMP CONVERSIONS [56](#)

R

RENOLD CHAIN [21, 22](#)
REPAIR MANUALS [66](#)
RING SETS [35](#)
ROCKER BOX PARTS [33](#)
ROCKER INSPECTION CAPS [36](#)

S

SEALS, ENGINE, GEARBOX, ETC. [14, 27](#)
SEALS, FRONT FORK [51, 52](#)
SEATS & COVERS [40](#)
SEAT HINGES [43, 44](#)
SERVICE MANUALS [66](#)
SHIFT LEVERS [18](#)
SHOCK ABSORBERS & SPRINGS [48](#)
SIDE COVERS & PANELS [41](#)
SIDE STANDS & PARTS [43, 44](#)
SIGNAL LAMPS & LENSES [57, 58](#)

S

SPEEDOMETER CABLES **63**
SPEEDOMETER GEARBOXES **63**
SPROCKETS, GEARBOX **13, 14**
SPROCKETS, REAR WHEEL **12**
STEERING BEARINGS & PARTS **50, 51**
SWING ARM BUSHINGS & PARTS **43, 44**
SWITCHES **59, 60**

T

TACHOMETER CABLES **63**
TAIL LAMPS, LENSES & BRACKETS **57, 58**
TAPPETS **34**
THROTTLE TWIST GRIPS **22**
TOOLS & TOOL KITS **64**
TRANSMISSION PARTS **14, 15, 16, 17, 18, 19, 20, 21**

V

VALVES & SPRINGS **32, 33**
VALVE GUIDES **31**

W

WHEEL PARTS **10, 11**
WIRE HARNESSSES **61**
WRENCHES **64**



AMAL

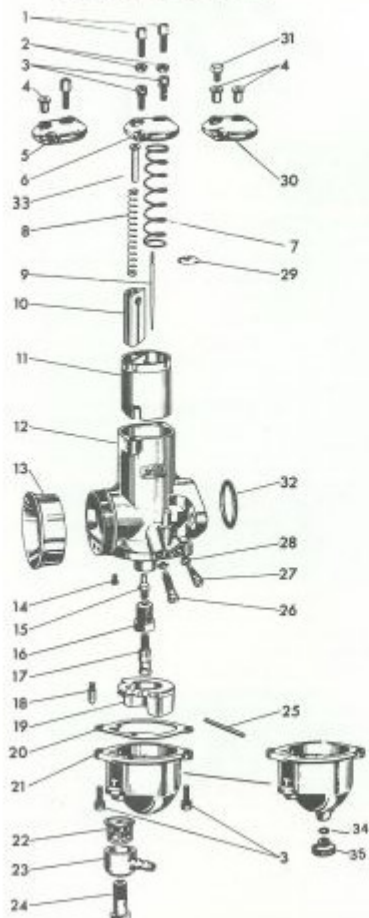

SERIES 600 & 900 CARBURETTER PARTS

KEY	COMPONENT	SERIES 600	SERIES 900
1	Cable adjuster	4-035	4-035
2	Cable adjuster locknut	5-077	5-077
3	Securing screw for float bowl and mixing chamber top	622-086	622-086
5	Mixing chamber top for adjuster and ferrule	---	928-097
6	Mixing chamber top (Standard)	---	928-064
7	Throttle slide spring	622-131	622-131
8	Choke Valve spring	622-129	622-129
9	Throttle needle (2 rings)	622-124	622-124
9	Throttle needle - Norton	---	928-104
10	Choke Valve	622-062	928-062
11	Throttle Slide (Specify cutaway 2 1/2, 3, 3 1/2, or 4	622-060	928-060
12	Carb Body (Specify RH or LH & Size)	R-L 626B	R-L 930B
13	Velocity stack, standard	376-066	928-066
14	Pilot jet (Specify Size)	124-026	124-026
15	Needle jet (Specify Size 105, 106, or 107)	622-122	622-122
16	Jet holder	622-128	622-128
17	Main Jet (Specify size ranging from 130 thru 290)	376-100	376-100
18	Float Needle (Viton Tip)	622-197	622-197
19	Float	622-069	622-069
20	Float Bowl washer	622-073	622-073
21	Float Bowl 0.10 in. seating with drain plug	622-055	622-055
22	Filter	376-093	376-093
23	Banjo, single, push on (1/4 in. inside diameter tubing)	376-097	376-097
24	Banjo Bolt	622-078	622-078
25	Float spindle	622-071	622-071
26	Throttle stop adjusting screw	622-077	622-077
27	Pilot air adjusting screw	622-076	622-076
28	"O" Rings	622-082	622-082
29	Needle Clip	622-067	622-067
30	Mixing chamber top for two ferrules	---	928-098
31	Plug for mixing chamber top	4-137A	4-137A
32	"O" Ring for flange sealing	622-101	622-101
33	Choke Valve Guide	622-134	928-103
34	Float bowl drain plug washer	622-151	622-151
35	Float bowl drain plug	622-147	622-147

NOTE: AMAL CARBURETTERS & LUCAS ELECTRICS ARE LISTED IN SEPARATE SECTIONS IN THE BACK OF THE PRICE SHEET.



AMAL CONCENTRIC CARBURETTERS COMPLETE

PART#	MODEL	RH/LH	BORE
L626	MK1	LH	26mm
R626	MK1	RH	26mm
L928	MK1	LH	28mm
R928	MK1	RH	28mm
L930	MK1	LH	30mm
R930	MK1	RH	30mm
L932	MK1	LH	32mm
R932	MK1	RH	32mm
L2930	MK2	LH	30mm
R2930	MK2	RH	30mm
L2932	MK2	LH	32mm
R2932	MK2	RH	32mm
L2934	MK2	LH	34mm
R2934	MK2	RH	34mm



**#622-235
UPDATE KIT**

For 600/900 Models, includes throttle needle #622-124, needle jet #622-122 size 106, and jet holder #622-128



**#622-238
CONCENTRIC REPAIR KIT**

For 600/900 Models, includes gaskets, "O" rings, float needle, needle clip, air adjuster screw, throttle adjuster screw and fuel filter

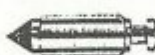

**#622-197
VITON FLOAT NEEDLE**

Rubber tipped for all MK 1 concentric and mono-bloc models



**#622-172
ALLOY TICKLER CONVERSION KIT**

Converts all MK 1 concentric models to a shrouded tickler

AMAL

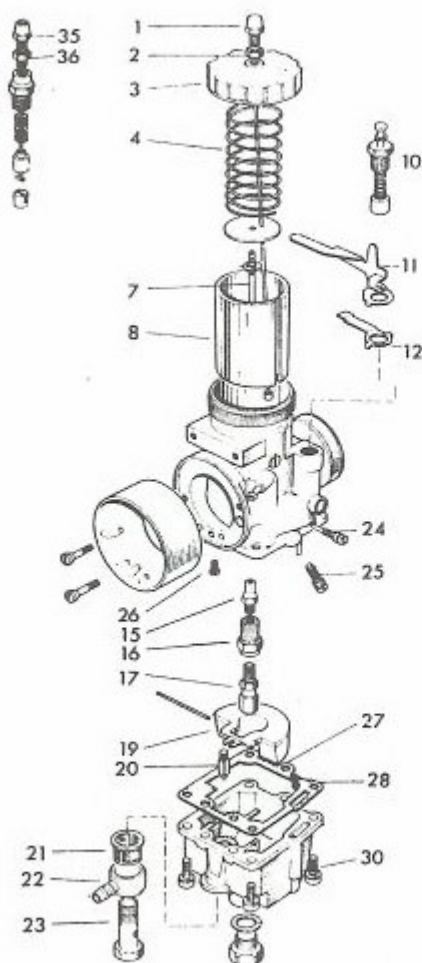

Mk 2 Concentric Carburetter Parts

1	CABLE ADJUSTER	4-035
2	CABLE ADJUSTER LOCKNUT	5-077
3	MIXING CHAMBER TOP	2928-064
4	THROTTLE SLIDE SPRING	2928-061
7	THROTTLE NEEDLE 2A1	2622-124
	THROTTLE NEEDLE 2C3	2928-030
	THROTTLE NEEDLE 2D2	2928-124
8	THROTTLE SLIDE (SPECIFY CUTAWAY)	2928-060
10	COLD START PLUNGER ASSY	2622-079
	COLD START KIT, CABLE OPERATED	2622-149
11	COLD START LEVER & BRACKET	2622-169
	COLD START LEVER & BRACKET ASSY	2622-075
12	COLD START CLICK SPRING	2622-087
15	NEEDLE JET (SPECIFY SIZE)	2928-122
	NEEDLE JET (SPECIFY SIZE)	2928-031
16	JET HOLDER	622-128
17	MAIN JET (SPECIFY SIZE)	376-100
19	FLOAT	622-069
20	FLOAT NEEDLE	622-149
21	FILTER	376-093
22	BANJO, SINGLE PUSH ON	376-097
23	BANJO BOLT	622-078
24	PILOT AIR ADJUSTING SCREW ASSY	2622-128
25	THROTTLE STOP ADJUSTING SCREW ASSY	2622-129
26	PILOT JET (SPECIFY SIZE)	124-026
27	FLOAT BOWL WASHER	2622-070
28	COLD START JET (SPECIFY SIZE)	124-026
30	SCREW, FLOAT BOWL SECURING	2622-086
35	ADJUSTER	4-035
36	ADJUSTER LOCK NUT	5-077
	NI RUBBER MANIFOLD ADAPTOR MK II	2928-123
	NI CLAMP, MANIFOLD ADAPTOR	2928-146
	NI GASKET SET, AMAL MARK II	2622-144
	NI REPAIR KIT, AMAL MARK II	2928-178

NOTE: AMAL CARBURETTERS & LUCAS ELECTRICS ARE LISTED IN SEPARATE SECTIONS IN THE BACK OF THE PRICE SHEET.

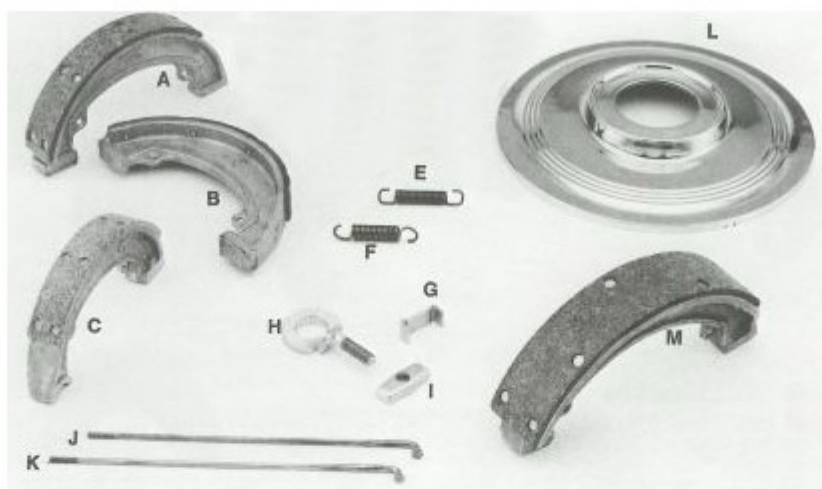

BRAKES & WHEELS

- A) #37-3925 Brake Shoe, Rear (Leading)**
B) #37-3926 Brake Shoe, Rear (Trailing)
 BSA (B50) & TRI TR5T 500 1971-74
 BSA/TRI 650/750 Twins 1971-74
 TRIDENT/BSA (A75) 750 1971-74
- C) #37-3804 Brake Shoe (6° Front)**
 BSA/TRI 250 1971
 BSA (B50) & TRI TR5T 500 1971 on
- E) #37-0135 Spring, Brake Shoe Return**
 Supersedes #42-5841
 Most Early TRI And Some BSA
- F) #37-2328 Spring, Brake Shoe Return**
 Supersedes #65-5904
 Later TRI and BSA Rear Brakes and Many Early BSA Applications
- G) #37-1415 Thrust Pad, Brake Shoe**
 Supersedes #41-6078 Most Applications
- H) #37-2089 Chain Adjuster**
 Supersedes #37-1134 (Use with #37-1015)
 TRI (except TR5T) 500 thru 1974
 TRI 650 thru 1970
 TRIDENT/BSA (A75) 750 thru 1970
- I) #37-1015 End Plate for Chain Adjuster**
 Supersedes #40-6040 (Use with #37-2089)
 Same applications as #37-2089 as well as BSA/TRI 250 & 441 thru 1970
- J) #37-1107 Spoke, Rear Wheel**
 (Short, left hand 7 9/16" with 90° angle)
- K) #37-1108 Spoke, Rear Wheel**
 (Long, right hand 7 7/8" with 90° angle)
 TRI 500 thru 1974
 TRI 650 thru 1970
- K) #37-3402 Spoke, Rear Wheel**
 (Short, left hand 7 9/16" with 110° angle)
 TRI 500 1969-74
 TRI 650 1969-70
 (Note: optional use on earlier outer left hand side)
- L) #37-3460 Chrome Cover Plate (Front Wheel)**
 TRI 500 1970-74
 BSA 650 1968-70
 TRI 650 1966-70
 BSA (A75)/TRIDENT 750 1969-70
- M) #37-1996/J Brake Shoe Set (8° Dual Leading Front)**
 TRI 500 (except TR5T) 1970-74
 BSA/TRI 650 Twins & BSA (A75) / TRIDENT ' 68-70



BRAKE & WHEEL PARTS

PART NO. DESCRIPTION & APPLICATION

- #37-7175 BRAKE DISC, TRI, WITH 4 HOLE PATTERN
- #37-7079 BRAKE DISC, TRI T140D, 6 HOLE PATTERN
- #99-2769J BRAKE PAD SET, TRI DISC BRAKE MODELS
- #06-1894J BRAKE PAD SET, NORTON DISC BRAKE MODELS
- #37-4263 BRAKE CALIPER COVER, TRI DISC BRAKE MODELS
- #37-1406/7 BRAKE SHOE SET, REAR, TRI TWINS, EARLY
- #37-2327 BRAKE SHOE, REAR, BSA THRU 1970
- #37-3713 BRAKE SHOE, FRONT 8", CONICAL HUB
- #06-3417 BRAKE SHOE SET, REAR, NORTON
- #06-0006 BRAKE SHOE SET, FRONT, NOR COMMANDO

PART NO. DESCRIPTION & APPLICATION

- #37-3585 BRAKE DRUM, REAR, TRI TWINS, EARLY (UNF)
- #37-3590 BRAKE SHOE PLATE, REAR TRI TWINS, EARLY
- #37-3857 BRAKE SHOE PLATE, REAR TRI TRST
- #37-3586 WHEEL HUB, REAR, TRI TWINS, EARLY
- #37-7041 WHEEL BEARING, 25 x 52 x 15mm, TRI, DISC BRAKE
- #37-7042 WHEEL BEARING, 20 x 47 x 14mm, TRI/BSA
- #82-7386 BRAKE ROD, TRI TWINS, EARLY, 21" LONG
- #83-2616 BRAKE ROD, BSA/TRI SINGLES, 18" LONG
- #83-2860 BRAKE ROD, TRI/BSA 650 TWINS 1971 ON, 20"
- #82-7387 ADJUSTER NUT, BRAKE ROD, 28 TPI



REAR WHEEL SPROCKETS

PART NO.	DESCRIPTION & APPLICATION
#37-1499	SPROCKET, 46T, EARLY TRI TWINS, 8 BOLT PATTERN
#37-3411	SPROCKET, 52T, TRI/BSA 3 CYL, 8 BOLT PATTERN
#37-3747	SPROCKET, 47T, TRI/BSA 650, 5 BOLT PATTERN
#37-4046	SPROCKET, 50T, TRI/BSA, 5 BOLT PATTERN
#37-3903	SPROCKET, 53T, TRI/BSA 3 CYL, 5 BOLT PATTERN
#37-7064	SPROCKET, 47T, TRI T140 DISC BRAKE, 4 BOLT
#37-7072	SPROCKET, 45T, TRI T140 DISC BRAKE, 4 BOLT
#37-7072/3	SPROCKET, 43T, TRI T140 DISC BRAKE, 4 BOLT
#37-7089	SPROCKET, 47T, TRI T140D DISC BRAKE, 6 BOLT
#37-7089/5	SPROCKET, 45T, TRI T140D DISC BRAKE, 6 BOLT
#37-2321	SPROCKET, 49T, BSA/TRI SINGLES THRU 1970
#37-3741/0	SPROCKET, 50T, BSA/TRI SINGLES 1971 ON
#37-3741	SPROCKET, 52T, BSA/TRI SINGLES 1971 ON
#68-6088	SPROCKET, 47T, BSA TWINS THRU 1970
#06-6011	SPROCKET, 42T, NORTON MK 3, DISC BRAKE



BAKE DRUM/SPROCKETS

PART NO.	DESCRIPTION & APPLICATION
#37-1276	BRAKE DRUM/SPROCKET, 43T, TRI EARLY TWINS
#37-0951/6	BRAKE DRUM/SPROCKET, 46T, TRI EARLY TWINS
#37-1040	BRAKE DRUM/SPROCKET, 46T, TRI QUICK DETACH
#06-2764	BRAKE DRUM/SPROCKET, 42T, NORTON 750/850

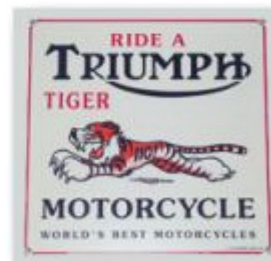

GEARBOX SPROCKETS

TRIUMPH

PART NO.	DESCRIPTION and APPLICATION
#57-1476/0	GEARBOX SPROCKET, 20T, TRI 500 TWINS
#57-1815/8	GEARBOX SPROCKET, 18T, TRI PRE-UNIT TWINS
#57-1815/9	GEARBOX SPROCKET, 19T, TRI PRE-UNIT TWINS
#57-1917/8	GEARBOX SPROCKET, 18T, TRI 650/750, 4 SPEED
#57-1919/1	GEARBOX SPROCKET, 21T, TRI 650/750, 4 SPEED
#57-4784	GEARBOX SPROCKET, 18T, TRI 650/750, 5 SPEED
#57-4782	GEARBOX SPROCKET, 20T, TRI 650/750, 5 SPEED
#57-7067	GEARBOX SPROCKET, 21T, TRI 650/750, 5 SPEED

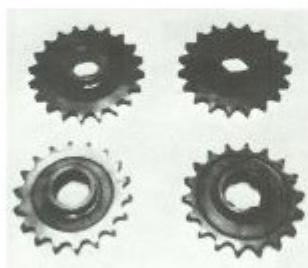

BSA

PART NO.	DESCRIPTION and APPLICATION
#57-4306	GEARBOX SPROCKET, 14T, BSA/TRI SINGLES
#57-2765	GEARBOX SPROCKET, 15T, BSA/TRI SINGLES
#57-2701	GEARBOX SPROCKET, 16T, BSA/TRI SINGLES
#57-2766	GEARBOX SPROCKET, 17T, BSA/TRI SINGLES
#67-3064	GEARBOX SPROCKET, 18T, BSA A10
#67-3065	GEARBOX SPROCKET, 19T, BSA A10
#68-3093	GEARBOX SPROCKET, 18T, BSA A65
#68-3078	GEARBOX SPROCKET, 19T, BSA A65
#68-3073	GEARBOX SPROCKET, 20T, BSA A65
#68-3089	GEARBOX SPROCKET, 21T, BSA A65

NORTON

PART NO.	DESCRIPTION and APPLICATION
#04-0480	GEARBOX SPROCKET, 19T, NORTON
#06-0931	GEARBOX SPROCKET, 20T, NORTON
#06-0721	GEARBOX SPROCKET, 21T, NORTON
#06-0759	GEARBOX SPROCKET, 22T, NORTON

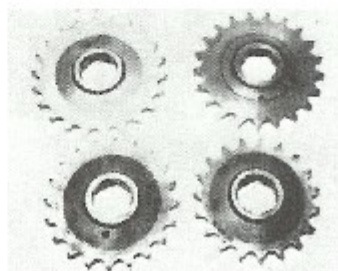

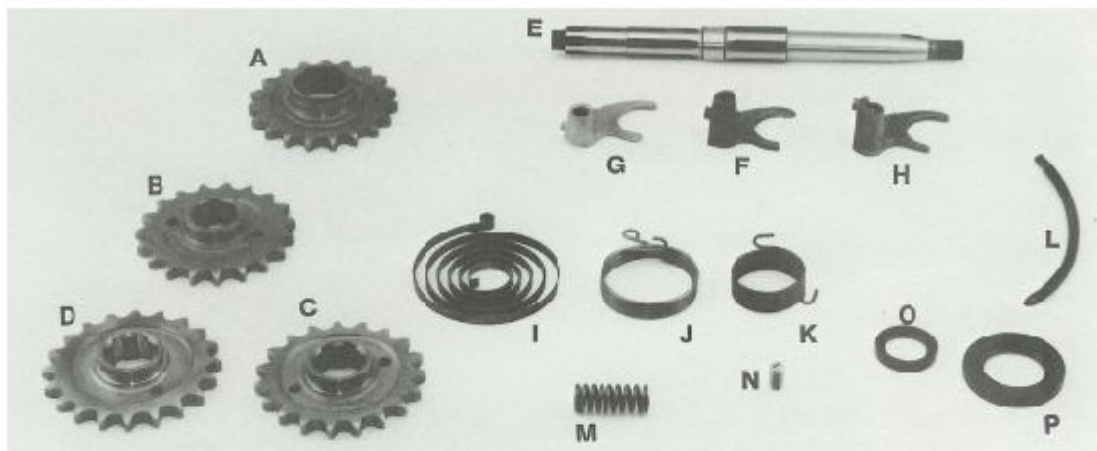

SPROCKETS, KICK START SPRINGS, FIVE SPEED TRANSMISSION, MISC...

- A) #57-4783 Gear Box Sprocket (19T)**
Five Speed Only
TRI 650/750 Unit Twins
TRIDENT/BSA (A75) 750 1971 & on
- B) #57-1476/8 Gear Box Sprocket (18T)**
TRI 500 Unit Twins
#57-1476/9 Gear Box Sprocket (19T)
TRI 500 Unit Twins
- C) #57-1918/9 Gear Box Sprocket (19T)**
Four Speed Only
TRI 650 Twins - All
TRIDENT/BSA (A75) 750 - All
- D) #57-1919/0 Gear Box Sprocket (20T)**
Four Speed Only
TRI 650 Twins - All
TRIDENT/BSA (A75) 750 - All
- E) #57-4432 Main Shaft**
Five Speed Only
TRI 650/750 Unit Twins 1971 & later
- F) #57-4366 Shift Fork (Lay Shaft 3rd Gear)**
Five Speed Only
TRI 650/750 Unit Twins 1971 & later
TRIDENT/BSA (A75) 750 1971-'75
- G) #57-4660 Shift Fork (Lay Shaft 1st Gear)**
Five Speed Only
TRI 750 Twins & TRIDENT 750 1973 & later
- H) #57-4364 Shift Fork (Main Shaft 4th Gear)**
Five Speed Only
TRI 650/750 Unit Twins 1971 & later
TRIDENT/BSA (A75) 750 1971-'75
- I) #57-0031 Kick Start Return Spring**
TRI 650/750 Twins
TRIDENT/BSA (A75) 750
- J) #57-2687 Kick Start Return Spring**
Supersedes #40-3275
TRI/BSA 250 & 441 - All
- K) #57-1441 Kick Start Return Spring**
TRI 500 Unit Twins - All
- L) #71-1078 Oiling Tube for Primary Chain**
TRI 650/750 Unit Twins 1970-'78
#70-4704 Oiling Tube for Primary Chain
TRI 650 Unit Twins thru 1969
- M) #57-4644 Clutch Spring**
TRI 750 Unit Twins 1973 & later
(Note: can be used as extra stiff spring for all unit, three spring clutches)
- N) #57-2159 Adjuster Screw for Pressure Plate**
Fits #57-4590 Pressure Plate, 3/8" diameter
TRI/BSA 500/650/750 Unit Twins with three spring clutch
- O) #70-7565 Oil Seal for Primary Case**
TRI 500 Twins 1968-'74
TRI 650 (Four Speed Only) 1968-'72
- P) #57-1478 Oil Seal for Gear Box Sprocket**
TRI 500 Unit Twins - All

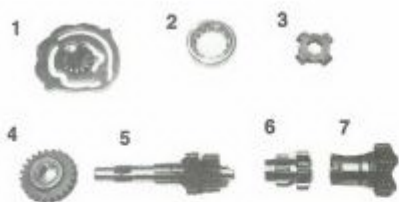

TRANSMISSION PARTS

- | | | |
|---|--|---|
| <p>1) #57-4889 CAMPLATE
5 Speed only (Supersedes #57-4360, #57-4624)
TRI 650/750 Twins
TRI/BSA Triples 1971 - 1975</p> <p>2) #60-4100 HIGH GEAR ROLLER BEARING
TRI/BSA 5 Speed only</p> <p>3) #57-4661 DRIVING DOG
1st GEAR L/S, 5 Speed Models
TRI 750 Twins & Triples 1973 on</p> <p>4) #57-4654 1st GEAR L/S (24T) 5 Speed Models
TRI 750 Twins & Triples 1973 on</p> <p>5) #57-4900 LAYSHAFT ASSY With 4th & 5th GEARS (15/17T)
5 Speed Models (Supersedes #57-4371, #57-4548)
TRI 650/750 Twins 1971 on
BSA/TRI Triples 1971 on</p> <p>6) #57-4653 1st & 2nd GEARS M/S (13/16T) 5 Speed Models
TRI Twins & Triples 1973 on</p> | <p>7) #57-4779 HIGH GEAR M/S (21T) WITHOUT ROLLER BEARING
5 Speed Models (Supersedes #00-5242, #57-4372, #57-4423, #57-4536, #57-4628, #57-4781)
TRI 650/750 Twins & Triples
BSA 750 A75 1971-72</p> <p>8) #57-4307 SHIFT FORK (Lay Shaft)
4 Speed Models (Supersedes #57-0913)
TRI 650 Twins thru 1972
TRI/BSA Triples 1969-1972</p> <p>9) #57-4308 SHIFT FORK (Main Shaft)
4 Speed Models (Supersedes #57-0260B)
TRI 650 Twins thru 1972
TRI/BSA Triples 1969 - 1972</p> <p>10) #57-4657 2nd GEAR L/S (21T)
5 Speed Models
TRI 750 Twins & Triples 1973 on</p> | <p>11) #57-4377 3rd GEAR M/S (18T)
5 Speed Models
TRI 650/750 Twins 1971 on
TRI/BSA Triples 1971 on</p> <p>12) #57-4647 3rd GEAR L/S (18T)
5 Speed Models
TRI 750 Twins & Triples 1973 on</p> <p>13) #57-4376 4th GEAR M/S (20T)
5 Speed Models
TRI 650/750 Twins 1971 on
TRI/BSA Triples 1971 on</p> <p>14) #57-0440 LOCK NUT
Gear Box Sprocket
TRI 650, 4 Speed Only</p> <p>15) #57-1370 HIGH GEAR BUSH
(Supersedes #57-4006)
TRI 650/750 4 Speed Only
#57-3857 2nd GEAR M/S (20T)
(not illustrated)
4 Speed Models (Supersedes #57-0916)
TRI 650 thru 1970
TRIDENT 1969 - 1970
BSA A75 1969 - 1971</p> |
|---|--|---|

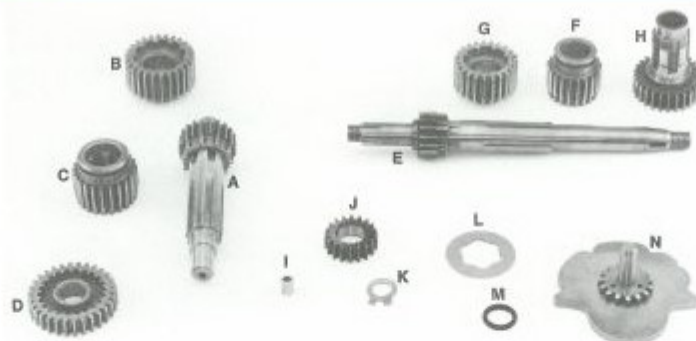

TRANSMISSION - FOUR SPEED, MISC. . .

- A) #57-4155 Lay Shaft with High Gear (20T)**
Supersedes #57-3864 - Four Speed Only
TRI 650 Twins 1968 - '70
TRIDENT/BSA (A75) 750 1969 - '70
- #57-4345 Lay Shaft with High Gear (19T)**
Four Speed Only
TRI 650 Twins & TRIDENT 750 1971 - '72
BSA (A75) 750 1972
- B) #57-3861 Second Gear - Lay Shaft (26T)**
Four Speed Only
TRI 650 Twins 1969 - '72
TRIDENT/BSA (A75) 750 1970 - '72
- C) #57-3890 Third Gear - Lay Shaft (22T)**
Four Speed Only
TRI 650 Twins 1970 - '72
TRIDENT/BSA (A75) 750 1970 - '72
- D) #57-3862 Low Gear - Lay Shaft (30T)**
Supersedes #57-0926 - Four Speed Only
TRI 650 Twins thru 1972
TRIDENT/BSA (A75) 750 1969 - '72
- E) #57-2436 Main Shaft with Low Gear (16T)**
Also #57-0914, #57-3893 - Four Speed Only
TRI 650 Unit Twins thru 1970
- #57-4158 Main Shaft, with Low Gear (16T)**
Four Speed Only
TRI 650 Twins 1971 - '72
- F) #57-4335 Second Gear - Main Shaft (20T)**
Four Speed Only
TRI 650 Twins, TRIDENT 750 1971 - '72
BSA (A75) 750 1972
- G) #57-3889 Third Gear - Main Shaft (23T)**
Supersedes #57-2378 - Four Speed Only
TRI 650 Twins 1969 - '72
TRIDENT/BSA (A75) 750 1970 - '72
- H) #57-3891 High Gear - Main Shaft (26T)**
Four Speed Only
TRI 650 Twins 1970
- #57-4332 High Gear - Main Shaft (25T)**
Four Speed Only
TRI 650 Twins 1971 - '72
- I) #57-3988 Clutch Rod Bushing**
Supersedes #68-3027, #PT108B
TRI 650/750 Twins - All
BSA 500/650 Twins - thru 1972
- J) #57-0730 Kick Start Pinion**
TRI 650/750 Twins - All
TRIDENT 750 1970 - '75
BSA (A75) 750 1971 - '72
- K) #57-2240 Tab Lock Washer (Main Shaft)**
Supersedes #57-0732
TRI 500 thru 1974
TRI 650/750 Twins - All
TRIDENT/BSA (A75) 750 - All thru 1975
- L) #57-2116 Tab Lock Washer (Gear Box Sprocket)**
Four Speed Only
TRI 650 Twins thru 1972
TRIDENT/BSA (A75) 750 1969 - '72
- M) #57-1956 Seal- Kick Start Shaft**
TRI 650/750 Twins - All
TRIDENT/BSA (A75) 750 thru 1975
- N) #57-4055 Gear Selector Complete**
Supersedes #57-0500, #57-3650
Four Speed Only
TRI 650 Twins thru 1972
TRIDENT/BSA (A75) 750 1969 - '72

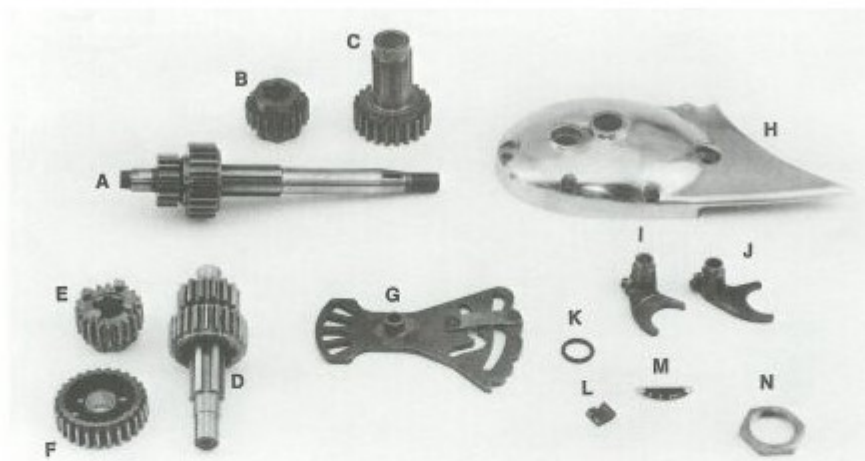

TRANSMISSION - 500 UNIT TWINS

- A) #57-4039 Main Shaft with Low (16T) and Third (24T) Gears**
Supersedes #57-2275
TRI 500 Twins (except TR5T) 1967 - '74
- B) #57-3994 Second Gear Main Shaft (21T)**
Supersedes #57-1922
TRI 500 Unit Twins thru 1974
- C) #57-3991 High Gear Main Shaft (22T)**
Supersedes #57-2318
TRI 500 Unit Twins 1968 - '74
- D) #57-4041 Lay Shaft with Second (23T) and High (15T) Gears**
Supersedes #57-1949
TRI 500 Unit Twins 1967 - '74

- E) #57-3997 Third Gear Lay Shaft (20T)**
Supersedes #57-1839
TRI 500 Unit Twins thru 1974
- F) #57-3999 Low Gear Lay Shaft (27T)**
Supersedes #57-1950
TRI 500 Unit Twins (except TR5T) thru 1974
- G) #57-4218 Gear Selector Camplate**
Supersedes #57-1768
TRI 500 Unit Twins thru 1974
- H) #57-3755 Cover Outer Gear Box**
TRI 500 Unit Twins 1969 - '74

- I) #57-1480 Shift Fork (Main Shaft)**
TRI 500 Unit Twins thru 1974
- J) #57-1481 Shift Fork (Lay Shaft)**
TRI 500 Unit Twins thru 1974
- K) #57-2239 Seal- Kick Start Shaft**
TRI 500 Unit Twins 1967 - '74
- L) #57-1431 Kick Start Pawl**
TRI 500 Unit Twins - All
- M) #57-1417 Gear Indicator Plate**
TRI 500 Unit Twins thru 1974
- N) #57-2536 Nut, Gear Box Sprocket**
TRI 500 Twins 1968 - '74

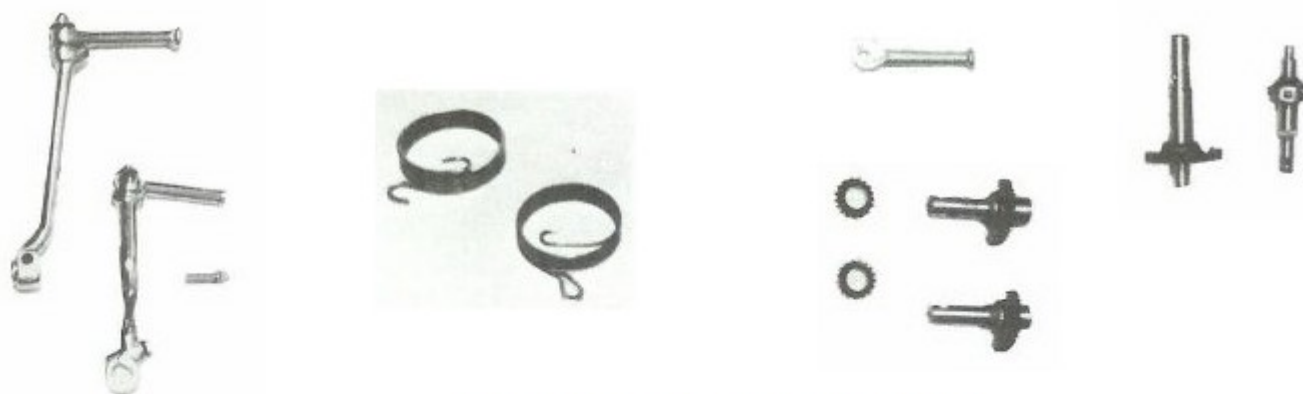

KICK START & SHIFT LEVERS, MISC PARTS

PART NO.	DESCRIPTION and APPLICATION
#57-2330	KICK RUBBER, TRI/BSA MOST MODELS, OPEN END
#03-3218	KICK RUBBER, NORTON, OPEN END
#JP21009	KICKSTART COTTER, TRI/BSA
#JP21010	KICKSTART COTTER, TRI/BSA, OVERSIZE
#57-7017	KICK PEDAL, TRI K/S LEVER
#JP21001	KICKSTART CRANK, TRI 500 TWINS
#57-4503	KICKSTART CRANK, TRI 500 TR5T
#JP21002	KICKSTART CRANK, TRI 650/750 TWINS
#JP21016	KICKSTART CRANK, NORTON COMMANDO
#57-4338	KICKSTART RETURN SPRING, BSA SINGLES 1971 ON
#68-3053	KICKSTART RETURN SPRING, BSA A65 TWINS
#57-1981	KICKSTART SPINDLE, TRI 500 TWINS
#57-4756	KICKSTART AXLE, TRI 650/750
#57-4117	KICKSTART QUADRANT, TRI 650/750

PART NO.	DESCRIPTION and APPLICATION
#57-4592	KICKSTART QUADRANT, BSA/TRI 250 1967 - 1970
#57-2683	KICKSTART PINION, BSA/TRI 250 1967 - 1970
#57-4336	KICKSTART PINION, BSA/TRI SINGLES 1971 ON
#57-2450	SHIFT RUBBER, TRI/BSA MOST MODELS, OVAL
#57-2331	SHIFT/CENTER STAND RUBBER, BARREL, OPEN END
#04-0086	SHIFT RUBBER, NORTON
#57-1435	SHIFT LEVER, TRI 500 TWINS
#57-3757	SHIFT LEVER, TRI 650/750 TWINS, RH SHIFT
#57-7010	SHIFT LEVER, TRI 750 TWINS, LH SHIFT
#57-3751	SHIFT LEVER, TRI 3 CYL MODELS
#57-1164	SHIFT LEVER, BSA SINGLES/TWINS
#57-4888	SHIFT SHAFT & QUADRANT, TRI 500 TWINS
#57-4116	SHIFT SHAFT & QUADRANT, BSA A65, 1966 - 1969

PRIMARY DRIVE & CLUTCH PARTS

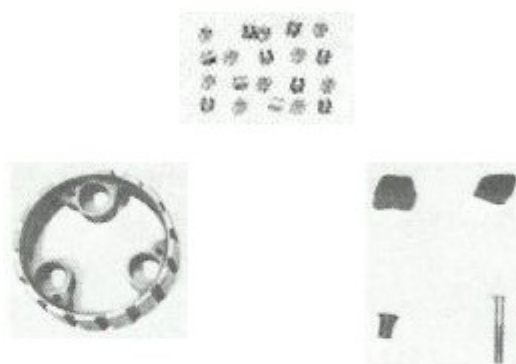

- | PART NO. | DESCRIPTION and APPLICATION |
|-----------------|---|
| #57-3983 | CHAIN ADJUSTER ROD, TRI/BSA 3 CYL, THRU 1973 |
| #70-4152 | CHAIN ADJUSTER ROD, TRI 500/650/750 UNIT TWINS |
| #70-9703 | CHAIN ADJUSTER NUT, TRI 500/650/750 UNIT TWINS |
| #70-6283 | CHAIN TENSIONER BLADE, TRI 500 TWINS, THRU 1974 |
| #70-6061 | CHAIN TENSIONER BLADE, TRI 650 TWINS, THRU 1972 |
| #70-5085 | CHAIN TENSIONER BLADE, TRI 750 TWINS, 1973 ON |
| #57-3610 | CHAIN TENSIONER BLADE, TRI/BSA 3 CYL, THRU 1973 |
| #57-4597 | CHAIN TENSIONER BLADE, TRID T150 1974 |
| #57-4937 | CHAIN TENSIONER BLADE, TRID T160 1975 |
| #57-1570 | CHAINWHEEL, TRI 500/650 TWINS, DUAL ROW |
| #57-4640 | CHAINWHEEL, TRI 750 TWINS, TRIPLE ROW |
| #57-1549 | CHAINWHEEL, TRI PRE-UNIT TWINS, SINGLE ROW |
| #57-2773 | CHAINWHEEL, BSA A65/A50 TWINS, THRU 1972 |

- | PART NO. | DESCRIPTION and APPLICATION |
|-----------------|---|
| #57-1719 | CLUTCH CENTER, TRI/BSA 500/650 TWINS, THRU 1971 |
| #57-4438 | CLUTCH CENTER, TRI 500/650/750 TWINS, 1972 ON |
| #42-3220 | CLUTCH CENTER, BSA A10, 6 SPRING HUB |
| #57-4511 | CLUTCH CENTER, BSA B50 SINGLE |
| #57-2538 | CLUTCH SPIDER, TRI/BSA 500/650 UNIT TWINS |
| #57-4636 | CLUTCH SPIDER, TRI 750 TWINS |
| #57-1722 | CLUTCH RUBBER, DRIVE, 3 SPRING CLUTCH |
| #57-1723 | CLUTCH RUBBER, REBOUND, 3 SPRING CLUTCH |
| #57-0394 | CLUTCH ROLLER, 1/4", TRI/BSA TWINS, PACK OF 20 |
| #57-2719 | CLUTCH ROLLER, 3/16", BSA/TRI SINGLES |
| #57-3931 | CLUTCH HUB THRUST WASHER, TRI/BSA TWINS |
| #57-3930 | CLUTCH HUB, TRI 500, UNIT TWINS |
| #57-3929 | CLUTCH HUB, TRI/BSA 650/750 UNIT TWINS |

CLUTCH PLATES SPRINGS, MISC.



- PART NO. DESCRIPTION and APPLICATION**
- #57-4763 CLUTCH PLATE, BONDED STEEL, TRI/BSA 500/650/750 TWINS
 - #57-4763B CLUTCH PLATE, BONDED STEEL, TRI/BSA 500/650/750 TWINS (BARNETT REPLACEMENT CLUTCH PLATE)
 - #57-4763J CLUTCH PLATE, BONDED STEEL, TRI/BSA 500/650/750 TWINS (ECONOMY REPLACEMENT CLUTCH PLATE)
 - #57-7058 CLUTCH PLATE, BONDED STEEL, TRI 750 TWINS 1981 ON
 - #57-1363 CLUTCH PLATE, DRIVEN STEEL, TRI/BSA 500/650/750 TWINS

 - #57-2726 CLUTCH PLATE, BONDED STEEL, BSA/TRI SINGLES
 - #57-2725 CLUTCH PLATE, DRIVEN STEEL, BSA/TRI SINGLES
 - #06-1339 CLUTCH PLATE, BONDED FIBRE, NORTON COMMANDO
 - #57-4590 PRESSURE PLATE, TRI/BSA TWINS, THREE SPRING CLUTCH

- PART NO. DESCRIPTION and APPLICATION**
- #57-1560 CLUTCH SPRING, TRI 500 & PRE-UNIT TWINS
 - #57-1830 CLUTCH SPRING, TRI/BSA 650 UNIT TWINS
 - #57-4644 CLUTCH SPRING, TRI 750 TWINS
 - #66-3800 CLUTCH SPRING, BSA, A10, 6 SPRING HUB
 - #57-2526 CLUTCH SPRING NUT, TRI/BSA UNIT TWINS
 - #57-4754 CLUTCH SPRING STUD, TRI/BSA UNIT TWINS
 - #57-1931 CLUTCH SPRING CUP, TRI/BSA UNIT TWINS
 - #57-7033 CLUTCH ACTIVATOR ASSY, TRI 650/750 TWINS, 1968 ON



3 CYLINDER CLUTCH PARTS

- PART NO. DESCRIPTION and APPLICATION**
- #57-3709 CLUTCH DRIVEN PLATE, TRI/BSA 3 CYL
 - #57-3708 CLUTCH PRESSURE RING, TRI/BSA 3 CYL
 - #57-4933 CLUTCH ACTIVATOR LEVER, TRI/BSA 3 CYL

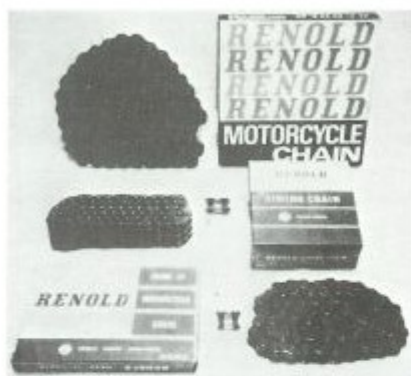

RENOLD
MOTORCYCLE CHAIN
PRIMARY DRIVE

PART NO.	DESCRIPTION	APPLICATION
#110046/70	SINGLE, 1/2" x 5/16" x 70 LINKS	TRI PRE-UNIT
#110046/76	SINGLE, 1/2" x 5/16" x 76 LINKS	NORTON
#114038/70	DUPLEX, 3/8" x 7/32" x 70 LINKS	BSA/TRI 250 SINGLES
#114038/72	DUPLEX, 3/8" x 7/32" x 72 LINKS	BSA 441/500 SINGLES
#114038/78	DUPLEX, 3/8" x 7/32" x 78 LINKS	TRI 500 TWINS
#114038/84	DUPLEX, 3/8" x 7/32" x 84 LINKS	TRI 650 TWINS
#114038/26	MASTER LINK, DUPLEX, 3/8" x 7/32"	
#116038/80	TRIPLEX, 3/8" x 7/32" x 80 LINKS	BSA A50/ A65 TWINS
#116038/82	TRIPLEX, 3/8" x 7/32" x 82 LINKS	TRI/BSA 3 CYL, THRU 1974
#116038/84	TRIPLEX, 3/8" x 7/32" x 84 LINKS	TRI 750 TWINS
#116038/92	TRIPLEX, 3/8" x 7/32" x 92 LINKS	NORTON COMMANDO
#116038/26	MASTER LINK, TRIPLEX, 3/8" x 7/32"	

ECONOMY CHAIN

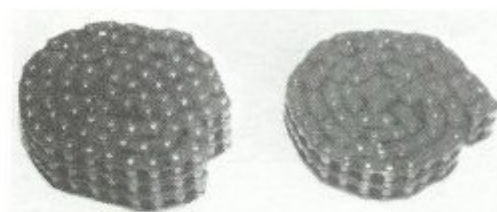

PART NO.	DESCRIPTION	APPLICATION
#JP82078	DUPLEX, 3/8" x 7/32" x 78 LINKS	TRI 500 TWINS
#JP82084	DUPLEX, 3/8" x 7/32" x 84 LINKS	TRI 650 TWINS
#JP83080	TRIPLEX, 3/8" x 7/32" x 80 LINKS	BSA A50/ A65 TWINS
#JP83082	TRIPLEX, 3/8" x 7/32" x 82 LINKS	TRI/BSA 3 CYL, THRU 1974
#JP83084	TRIPLEX, 3/8" x 7/32" x 84 LINKS	TRI 750 TWINS
#JP83092	TRIPLEX, 3/8" x 7/32" x 92 LINKS	NORTON COMMANDO

DID YOU KNOW WE
PAY FREIGHT ON ORDERS OVER \$300 (U.S. 48 STATES)
Oversized packages, additional handling packages and hazardous packages do not qualify for free freight. Examples are: frames, motors, tires, etc:

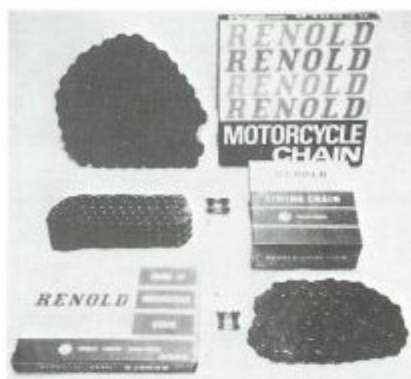

RENOLD
MOTORCYCLE CHAIN
REAR DRIVE

PART NO.	DESCRIPTION	APPLICATION
*#110054/-	REAR DRIVE #520, 5/8" x 1/4" PITCH	MOST TRI, BSA SINGLES
*#110056/-	REAR DRIVE #530, 5/8" x 3/8" PITCH	MOST TRI, BSA, NORTON TWINS & TRIPLES
#110056/26	MASTER LINK, #530 CHAIN	
#110056/30	CHAIN LINK, OFFSET HALF LINK #530 CHAIN	

* PLEASE REFER TO THE PRICE SHEET FOR A LISTING OF CHAIN LENGTHS AVAILABLE.

CONTROL LEVERS, TWIST GRIPS & MIRRORS



PART NO.	DESCRIPTION & APPLICATION
#60-3980	LEVER BLADE, BRAKE, CHROME STEEL, TRI/BSA 1971 - 1972
#60-3994	LEVER BLADE, CLUTCH, CHROME STEEL, TRI/BSA 1971 - 1974
#60-4206	LEVER BLADE, BRAKE, TRI DISC BRAKE MODELS, THRU 1978
#LA219L	CLUTCH LEVER ASSY, (LH) UNIVERSAL 7/8", CHROME STEEL
#LA219R	BRAKE LEVER ASSY, (RH) UNIVERSAL 7/8", CHROME STEEL
#60-3246	CHOKE/MAG CONTROL ASSY, 7/8" BARS
#JP40002	CABLE ADJUSTER, WITH NUT, SLOTTED TYPE, BRAKE/CLUTCH
#JP40005	CABLE STOP, THROTTLE CONTROL
#TG715	THROTTLE TWISTGRIP, SINGLE CABLE, 7/8" BARS
#TG71D	THROTTLE TWISTGRIP, DUAL CABLE, 7/8" BARS
#JP52000	MIRROR, FITS CONTROL LEVER, TRI/BSA 1969 ON
#60-7249	MIRROR, OEM. STYLE BLACK, TRI T140, 1979 ON
#MR_	MIRROR, CLAMP-ON STYLE, SPECIFY 4", 8" OR 10"

CONTROL CABLES



BRAKE

PART NO.	DESCRIPTION & APPLICATION
#60-0559	BRAKE CABLE, TRI 650 TWINS 1966 - 1967
#60-0665	BRAKE CABLE, TRI TWINS 1968
#60-2076	BRAKE CABLE, WI SWITCH, TRI TWINS 1969 - 1970
#60-2076P	BRAKE CABLE, SAME AS 60-2076, BUT NO SWITCH
#60-3557	BRAKE CABLE, TRI/BSA 650, 1971 - 1972
#60-3557P	BRAKE CABLE, SAME AS 60-3557, BUT NO SWITCH
#68-8600	BRAKE CABLE, BSA TWINS SINGLE LEADING SHOE, 1966 - 1968

CLUTCH

PART NO.	DESCRIPTION & APPLICATION
#60-1994	CLUTCH CABLE, TRI 500 1962 ON
#60-0565	CLUTCH CABLE, TRI 650 1963 - 1967
#60-1993	CLUTCH CABLE, TRI 650 1968 - 1972
#60-3925	CLUTCH CABLE, TRI 750 TWINS, NYLON LINED
#60-4168	CLUTCH CABLE, TRI 750 TWINS, NYLON, UK BAR
#60-2445	CLUTCH CABLE, TRI/BSA 3 CYL
#60-4454	CLUTCH CABLE, TRI 3 CYL T160
#60-2083	CLUTCH CABLE, BSA/TRI SINGLES
#68-8611	CLUTCH CABLE, BSA TWINS 1963 - 1969
#60-3077	CLUTCH CABLE, BSA TWINS 1970 ON
#06-2813	CLUTCH CABLE, NORTON COMMANDO

THROTTLE

PART NO.	DESCRIPTION & APPLICATION
#60-1823	THROTTLE CABLE, TRI 500 SINGLE CARB 1969 ON
#60-1822	THROTTLE CABLE, TRI 500 TWIN CARB 1969 ON
#60-0519	THROTTLE CABLE, TRI 650 TR6 1964 - 1967
#60-0746	THROTTLE CABLE, TRI 650 TR6 1968 - 1970
#60-1806	THROTTLE CABLE, TRI TR6/TR7 1971 ON
#60-0528	THROTTLE CABLE, TRI T120 1966 - 1967
#60-0660	THROTTLE CABLE, TRI T120 1968
#60-1819	THROTTLE CABLE, TRI T120/T140 1969 - 1975
#60-7001	THROTTLE CABLE, UPPER, TRI T140 1976 - 1978
#60-0733	THROTTLE CABLE, LOWER, TRI T140 1976 - 1978
#60-7149	THROTTLE CABLE, UPPER, TRI T140 MKII CARBS
#60-7084	THROTTLE CABLE, LOWER, TRI T140 MKII CARBS
#60-7427	THROTTLE CABLE, UPPER, TRI T140 BING CARBS
#60-7505	THROTTLE CABLE, LOWER, TRI T140 BING CARBS
#60-0890	THROTTLE CABLE, TRI/BSA 3 CYL THRU 1974
#60-4458	THROTTLE CABLE, TRI 3 CYL T160
#60-0804	THROTTLE CABLE, BSA 650 SINGLE CARB 1968 ON
#68-8678	THROTTLE CABLE, BSA 650 TWIN CARB 1966 - 1967
#60-0813	THROTTLE CABLE, BSA 650 TWIN CARB 1968 ON
#60-0962	THROTTLE CABLE, BSA/TRI 250-500 SINGLES
#06-1451	THROTTLE CABLE, UPPER, NOR COMM (EXCEPT MK3)
#03-3145	THROTTLE CABLE, LOWER, NORTON COMMANDO

CHOKE

PART NO.	DESCRIPTION & APPLICATION
#60-1807	CHOKE CABLE, TRI TR6/TR7 SINGLE CARB
#60-1818	CHOKE CABLE, UPPER, TRI 650 TWIN CARB
#60-3486	CHOKE CABLE, LOWER, TRI 650 TWIN CARB
#60-4127	CHOKE CABLE, UPPER, TRI T140 1973 - 1978
#60-4128	CHOKE CABLE, LOWER, TRI T140 1973 - 1978

NOTE: PLEASE REFER TO THE PRICE SHEET FOR
ADDITIONAL CABLE LISTINGS.



AIR FILTERS & ELEMENTS

- 1) **#60-2567 AIR FILTER ASSY**
(Supersedes #70-9074) 3 CYL
TRI 750 T150, 1969 - 1973
BSA 750 A75, 1971 - 1972
- 2) **#70-9138 AIR FILTER ELEMENT**
3 CYL, Gauze
TRI 750 T150, 1969 - 1973
BSA 750 A75, 1971 - 1972
- 3) **#83-5092 AIR FILTER ELEMENT**
3 CYL, Paper
TRI 750 T160, 1975
- 4) **#60-4265 AIR FILTER ELEMENT**
Gauze With Square Hole
(Supersedes #60-3072, #60-3618)
TRI 750 Twins 1973 on
TRI/BSA 650 Twins 1971 - 1972
- 5) **#60-2601 AIR FILTER ELEMENT**
Paper
TRI/BSA 250 1971
BSA 500, B50 1971 - 1973
TRI 500, TR5T 1973

- 6) **#82-5694 AIR FILTER ELEMENT**
Paper, For all Amal Carbs with
Round Style Filter
BSA 441 Thru 1970
TRI 500 Thru 1974 (except TR5T)
TRI/BSA 650 Thru 1970
- 7) **#82-6866 AIR FILTER ELEMENT**
Gauze, For all Amal Carbs with
Round Style Filter (Supersedes
#19-5593, #82-4811, #82-5764)
BSA 441 Thru 1970
TRI 500 Thru 1974 (except TR5T)
TRI/BSA 650 Thru 1970
- 8) **#60-4274 AIR FILTER ELEMENT**
Paper
TRI 500, TR5T 1974 Only

- 9) **#JP70001 AIR FILTER ASSY**
Center Mount Style, For Series 900
Amal Carbs, Threaded & Complete With
Filter Element, for Triumph & BSA
Models
**PLEASE REFER TO THE PRICE
SHEET FOR OTHER AMAL STYLE
FILTER ASSY'S (JP70002 - JP70006)**



**#82-9563 AIR FILTER
BREATHER TUBE**
TRI 750 T150, 1969 - 1974



HOSES & LINES, MISC

#60-4244 FLEX HOSE Upper
Master Cylinder to Top Yoke
(Supersedes #60-4176)
TRI Front Disc thru 1978

#60-7174 FLEX HOSE Upper
Master Cylinder to Top Yoke
Slightly Longer Than #60-4244
TRI Front Disc 1979 on

#60-4177 FLEX HOSE Upper
Master Cylinder to Top Yoke
(Supersedes #60-4619, #06-6235)
For Low Bars - Short
TRI Front Disc Models

#60-4175 FLEX HOSE Lower
Bottom Yoke to Caliper
(Supersedes #06-6243)
TRI Front Disc Models

#60-7028 FLEX HOSE Rear
Master Cylinder to Caliper
(Supersedes #60-4617, #60-4414,
#06-6218)
TRI Rear Disc, 1975 to Early 1979

#60-4409 RESERVOIR HOSE, Rear
Reservoir to Master Cylinder
TRI 750 Twins 1976 to Early 1979
TRI 750 (T160) 1975

#60-4178 BRAKE LINE, Metal
Front Caliper to Lower Flex Hose
TRI Front Disc Models

#60-4179 BRAKE LINE, Metal
Lower Flex Hose to Fork Yoke
TRI Front Disc Models thru 1978
Except TRI T160

#60-7007 BRAKE LINE, Metal
Rear Caliper to Flex Hose
TRI Rear Disc Models 1976 - 1979
Except Late Edition 1979

HYDRAULIC BRAKE PARTS

#60-4102 MASTER CYLINDER ASSY, FRONT
TRI Disc Brake Models Thru 1978

#60-7163 MASTER CYLINDER ASSY, FRONT
TRI Disc Brake Models 1979 on

#60-7686 MASTER CYLINDER ASSY, FRONT
TRI Disc Brake Models 1983

#60-4401 MASTER CYLINDER ASSY, REAR
TRI Disc Brake Models

#99-2753 HOUSING & LEVER BRACKET
For Master Cylinder #97-4102
TRI Disc Brake Models Thru 1978

#60-7164 HOUSING & LEVER BRACKET
For Master Cyl #60-7163, #60-7686
TRI Disc Brake Models 1979 on

#60-4397 RESERVOIR Master Cylinder
TRI Disc Brake Models, Front & Rear

#60-4365 CAP For Master Cylinder
(Supersedes #06-5740, #99-2751)
TRI Disc Brake Models, Front & Rear
NORTON 850 MK3

#60-4366 DIAPHRAGM
For Master Cylinder Cap
(Supersedes #97-2752)
TRI Disc Brake Models, Front & Rear

#60-4206 BRAKE LEVER BLADE
TRI Disc Brake Models Thru 1978

MASTER CYLINDER REPAIR KITS

#99-2768 MASTER CYLINDER REPAIR KIT
Front Brake Cylinder
TRI 750 Twins/Triples 1973 - 1978

#99-7022 MASTER CYLINDER REPAIR KIT
Rear, Lockheed only
TRI 750 Twins 1976 on
Front Brake Cylinder
TRI 750 Twins 1979 on
(Can Also be Used for 1973 - 78 Models)

#06-4244 MASTER CYLINDER REPAIR KIT
NORTON COMMANDO, Front

**CALIPER REPAIR KITS**

#99-7006 CALIPER REPAIR KIT
Front & Rear, Lockheed only
TRI 750 Twins/Triples 1973 on

#06-4243 CALIPER REPAIR KIT
NORTON COMMANDO, Front

OIL SEALS - ENGINE & GEARBOX

PART NO.	APPLICATION	MAKE - MODELS	YEAR	Supersedes
#70-4568	CONTACT POINTS SEAL Also used as CRANK OIL FEED (Tri Twins)	TRI TWINS/TRIPLES BSA 650 BSA A75	1963 on 1969-72 1969-72	76-0291 40-3281
#70-4568J	CONTACT POINTS SEAL	Economy Replacement		
#68-0026	CONTACT POINTS SEAL	BSA A65/A50	Thru 1968	
#70-8153	CONTACT POINTS SEAL	BSA/TRI SINGLES	Thru 1973	
#06-3609	CONTACT POINTS SEAL	Norton Commando		
#70-8154	CRANK TIMING SIDE SEAL	BSA/TRI SINGLES	Thru 1973	
#70-3876	CRANK DRIVE SIDE SEAL	TRI 650 TRI 500	1963-70 1959-69	
#70-3876J	CRANK DRIVE SIDE SEAL	Economy Replacement		
#67-0674	CRANK DRIVE SIDE SEAL	BSA TWINS	Thru 1972	
#67-0674J	CRANK DRIVE SIDE SEAL	Economy Replacement		
#70-7565	SPROCKET COVER SEAL	TRI 500/650 4 SPD	1968-72	
#70-4578	SPROCKET COVER SEAL	TRI 650 BSA A65/A50	1963-67 Thru 1972	68-0235
#70-4578J	SPROCKET COVER SEAL	Economy Replacement		
#60-3500	SPROCKET COVER/ HIGH GEAR SEAL	TRI TWINS/TRIPLES 5 SPD	1971 on	
#60-3500J	SPROCKET COVER SEAL	Economy Replacement		
#57-1478	G/BOX SPROCKET SEAL	TRI 500	Thru 1974	
#57-0946	G/BOX SPROCKET SEAL	TRI 650 4 SPD BSA A65/A50	Thru 1971 Thru 1972	68-0027
#57-0946J	G/BOX SPROCKET SEAL	Economy Replacement		
#04-0132	G/BOX SPROCKET SEAL	Norton Commando		
#60-3512J	G/BOX SPROCKET SEAL	TRI 650/750 TWINS 5 SPD	1971 on	
#57-3634	G/BOX SPROCKET SEAL	TRI/BSA 3 CYL, 4 SPD	Thru 1972	
#60-3510	G/BOX SPROCKET SEAL	TRI 750 3CYL, 5 SPD	Thru 1975	
#57-3642	MAINSHAFT SEAL	TRI/BSA 3 CYL	Thru 1975	
#57-3644J	CLUTCH PULLROD SEAL	TRI/BSA 3 CYL	Thru 1975	
#57-2239	K/START SHAFT SEAL	TRI 500	Thru 1974	
#57-2641	K/START SHAFT SEAL	BSA/TRI SINGLES	Thru 1973	
#57-1956	K/START SHAFT SEAL	TRI 650/750 TWINS TRI/BSA 3 CYL	1964 on Thru 1975	
#57-1956J	K/START SHAFT SEAL	Economy Replacement		

NOTE: SEALS ENDING IN "J" ARE GOOD QUALITY REPLACEMENT ITEMS MADE TO ORIGINAL SPECIFICATIONS

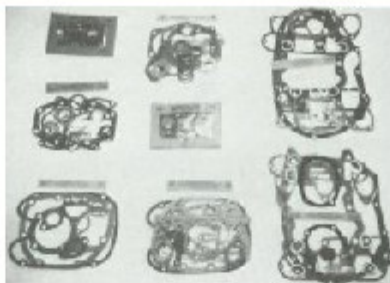

GASKET SETS

ENGINE SET PART NO.	TOP END SET ONLY PART NO.	MAKE	MODEL	YEAR
#G820	#GD820	TRI	500 T100 TWINS	1965 - 1969
#G828	#GD828	TRI	500 T100 TWINS	1970 - 1974
#G812		TRI	650 TWINS T110, TR6	1956 - 1962
#G815		TRI	650 TWINS T120	1959 - 1962
#G818		TRI	650 TWINS	1963 - 1966
#G822		TRI	650 TWINS	1967 - 1968
	#GD823	TRI	650 TWINS	1963 - 1968
#G826	#GD826	TRI	650 TWINS	1969 - 1970
#G832	#GD832	TRI	650 TWINS	1971
#G833	#GD833	TRI	650 TWINS	LATE 1971 - 1972
#G836	#GD836	TRI	750 TWINS	1973 on
#G841 (complete)		TRI	750 TWINS	1973 on
#G825	#GD825	TRI/BSA	T150-A75 TRIPLES	1969 - 1972
#G837	#GD837	TRI	T150 TRIPLES	1973 - 1974
#G839	#GD839	TRI	T160 TRIPLES	1975
#G335	#GD335	BSA/TRI	250 SINGLES	1967 - 1970
#G835	#GD835	BSA/TRI	250 SINGLES	1971 - 1972
#G332	#GD332	BSA	440 SINGLES	1964 - 1970
#G339	#GD339	BSA	500 B50 SINGLES	1971 - 1973
#G320C		BSA	650 A10 TWINS	1950 - 1962
#G337	#GD337	BSA	500 A50 TWINS	1963 - 1970
#G330	#GD330	BSA	650 A65 TWINS	1963 - 1966
#G334	#GD334	BSA	650 A65 TWINS	1967 - 1970
#G338	#GD338	BSA	650 A65 TWINS	1971 - 1972
#G269	#GD269	NOR	750 COMMANDO	1968 - 1973
#G270	#GD270	NOR	850 COMMANDO	1973 - 1975
#G271	#GD270	NOR	850 COMMANDO MK3	1975 on

NOTE: PLEASE REFER TO PRICE SHEET FOR ADDITIONAL LISTINGS.

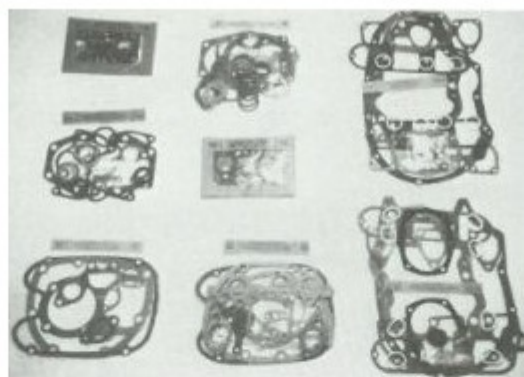

INDIVIDUAL GASKETS

PART NO. DESCRIPTION

#71-1420 ALTERNATOR ROTOR COVER, BSA
 #71-1457 ALTERNATOR ROTOR COVER, TRI
 #71-1416 CARB TO MANIFOLD
 #71-1453 CHAIN CASE, INNER, 3 CYL
 #71-1449 CLUTCH INSPC, TRI/BSA 3 CYL
 #70-3798 CYLINDER BASE, TRI 500 TWINS
 #70-6309 CYLINDER BASE, TRI 650/750
 #71-7634 CYL BASE, TRI 750 8 VALVE
 #70-6496 CYLINDER BASE, TRI/BSA 3 CYL
 #70-7823 CYL BASE, BSA, A65 THRU 1969
 #71-1433 CYL BASE, BSA TWINS 1970 ON
 #06-3995 EXHAUST PIPE/HEAD, NORTON
 #622-073 FLOAT BOWL, CONCENTRIC
 #2622-070 FLOAT BOWL, MKII
 #376-078 FLOAT COVER, MONO-BLOC
 #82-4048 GAS CAP
 #65-0323B GEARBOX INNER, TRI 500
 #65-0324B GEARBOX OUTER, TRI 500
 #65-0318B GEARBOX INNER, TRI 650 4 SPD

PART NO. DESCRIPTION

#57-7012 GEARBOX INNER, TRI LH SHIFT
 #71-1447 G/BOX INNER, TRI 3 CYL - 1974
 #71-1448 GEARBOX OUTER, TRI 4 & 5 SPD
 #04-0030 GEARBOX INNER, NORTON
 #04-0055 GEARBOX OUTER, NORTON
 #82-4047 OIL CAP, FORK STANCHION
 #71-3754 OIL JCT BLOCK, TRI TWINS
 #71-1461 OIL PUMP, TRI TWINS
 #71-3910 OIL PUMP, TRI 750 TWINS
 #71-1462 POINTS COVER, TRI TWINS
 #57-2581 PRIMARY CASE, 3 CYL EARLY
 #71-1454 PRIMARY CASE, 3 CYL LATE
 #06-5534 PRIMARY CASE, NORTON MK.III
 #70-9511 ROCKER BOX, TRI 500
 #70-9348 ROCKER BOX, TRI 650 THRU 1970
 #71-2599 ROCKER BOX, TRI 650/750 1971 ON
 #70-8773 ROCKER BOX, TRI/BSA 3 CYL
 #71-1427 ROCKER BOX, BSA B44, C15
 #70-1577 ROCKER & SUMP CAP, TRI

PART NO. DESCRIPTION

#70-3751 ROCKER CAP, TRI TWINS
 #71-2574 ROCKER COVER, TRI 650, 4 BOLT
 #71-3673 ROCKER COVER, TRI 750 TWINS
 #71-7277 ROCKER COVER, IN, TRI 8 VALVE
 #71-7276 ROCKER COVER, EX, TRI 8 VALVE
 #71-1445 ROCKER COVER, TRI/BSA 3 CYL
 #71-1431 ROCKER COVER, BSA TWINS - 1970
 #71-2207 ROCKER COVER, BSA TWINS, 71-2
 #06-7551 ROCKER COVER, REAR, NORTON
 #06-7554 ROCKER COVER, FRONT, NORTON
 #71-1419 SPROCKET COVER, TRI/BSA
 #71-1444 SUMP COVER, TRI/BSA 3 CYL
 #70-0487 SUMP PLATE, TRI PRE-UNIT
 #83-2829 SUMP, FRAME, TRI/BSA 650/750
 #71-1424 SUMP PLATE, BSA TWINS
 #65-0321B TIMING COVER, TRI 500 TWINS
 #71-7263 TIMING COVER, TRI 650/750 TWINS
 #71-1350 TIMING COVER, TRIDENT
 #71-1437 TIMING COVER, INNER BSA TWINS

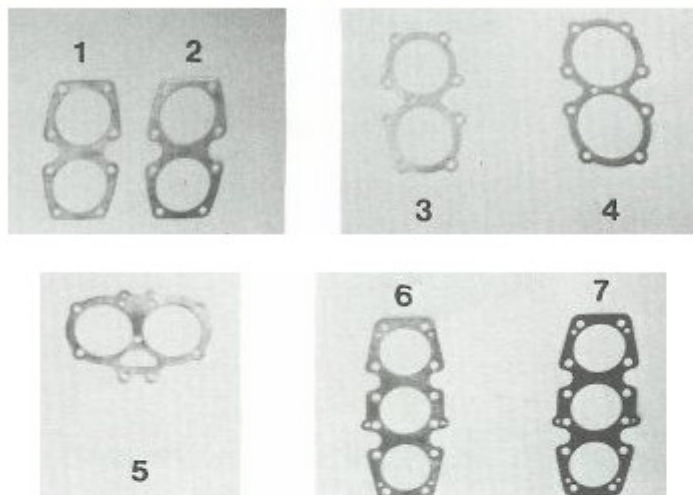

CYLINDER HEAD GASKETS

PART NO.	MAKE	MODEL	YEAR	
1) #70-4675	TRI	500 T100 (Thin)	Thru 1974	(c)*
2) #70-4675HD	TRI	500 T100 (Thick)	Thru 1974	(c)*
3) #70-4547	TRI	650 Unit Twins	1963-1972	(c)*
4) #71-3681	TRI	750 T140/TR7	1973 on	(c)*
#71-4619	TRI	750 T140	1973 on	(a)*
5) #68-0827	BSA	650 A65 Twins	Thru 1972	(c)*
6) #71-4250	TRI	750 TRIDENT T160	1975	(c)*
7) #71-1733	TRI/BSA	750 3 CYL T150/A75	1969-1974	(a)*

*(c) = copper, (a) = asbestos

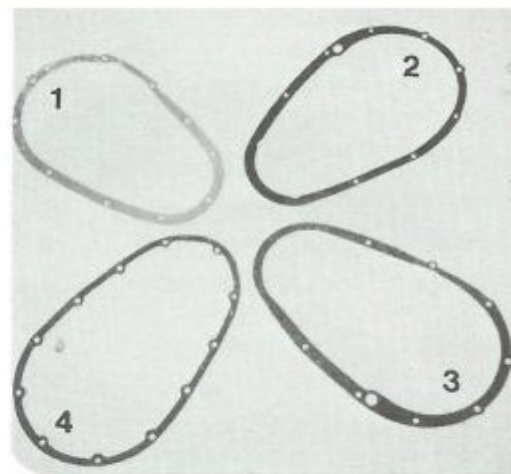

PRIMARY CASE GASKETS

- 1) #71-1456 TRI 500 Unit Twins Thru 1974
(Supersedes #70-4156)
- 2) #71-1463 TRI 650/750 Unit Twins 1963-1975
(Supersedes #57-1770)
- 3) #71-7009 TRI 750 T140 Twins 1976 on
- 4) #71-1432 BSA 500/650 Unit Twins A50/A65
(Supersedes #68-0241, #70-7854)



VALVE GUIDES

TRIUMPH

PART NO.	DESCRIPTION and APPLICATION
#JP10110B	VALVE GUIDE, INTAKE & EXHAUST, TRI 500, BRONZE
#JP10122B	VALVE GUIDE, INTAKE, TRI 650/750 TWINS, BRONZE
#JP10124B	VALVE GUIDE, EXHAUST, TRI 650/750 TWINS, BRONZE
#JP10142B	VALVE GUIDE, INTAKE, TRI 750, 1979 - 1981, BRONZE
#JP10143B	VALVE GUIDE, INTAKE, TRI 750, 1981 ON, BRONZE
#JP10144B	VALVE GUIDE, EXHAUST, TRI 750, 1979 ON, BRONZE
#JP10172B	VALVE GUIDE, INTAKE, TRI TSS, 8 VALVE, BRONZE
#JP10174B	VALVE GUIDE, EXHAUST, TRI TSS, 8 VALVE, BRONZE
#JP10150B	VALVE GUIDE, INTAKE & EXHAUST, TRI/BSA 3 CYL. BRONZE

BSA

PART NO.	DESCRIPTION and APPLICATION	PART NO.
#JP10220B	VALVE GUIDE, INT & EXH, BSA/TRI SINGLES, THRU 1970, BRONZE	
#JP10230B	VALVE GUIDE, INT & EXH, BSA/TRI SINGLES, 1971 ON, BRONZE	
#JP10260B	VALVE GUIDE, INTAKE & EXHAUST, BSA TWINS, THRU 1970 BRONZE	
#JP10280B	VALVE GUIDE, INTAKE & EXHAUST, BSA A65, 1971 ON, BRONZE	

NORTON

PART NO.	DESCRIPTION and APPLICATION
#JP10322B	VALVE GUIDE, INTAKE, NORTON COMMANDO 750, BRONZE
#JP10324B	VALVE GUIDE, EXHAUST, NORTON COMMANDO 750, BRONZE
#JP10342B	VALVE GUIDE, INTAKE, NORTON COMMANDO 850, BRONZE
#JP10344B	VALVE GUIDE, EXHAUST, NORTON COMMANDO 850, BRONZE

NOTE: PLEASE REFER TO THE PRICE SHEET FOR A MORE COMPLETE LISTING, INCLUDING AVAILABLE OVERSIZES.



INTAKE VALVES

PART NO.	DESCRIPTION	MFG#	APPLICATION
#70-6853	INTAKE VALVE	(V265)	TRI 500 UNIT TWINS
#70-2903	INTAKE VALVE	(V23)	TRI 650 TWINS, TO 1958
#70-3310	INTAKE VALVE	(V137)	TRI 650 TWINS, 1958 - 1963
#70-4603	INTAKE VALVE	(V245)	TRI 650/750 UNIT TWINS
#70-6422	INTAKE VALVE	(V270)	TRI/BSA 3 CYL MODELS TO 1973
#71-3361	INTAKE VALVE	(V282)	TRI 3 CYL MODELS, 1973 - 1975
#70-8112	INTAKE VALVE	(V255)	BSA/TRI 250 SINGLES/ BSA A50 TWINS
#41-0788	INTAKE VALVE	(V268)	BSA B44, SINGLES
#71-1735	INTAKE VALVE	(V272)	BSA B50, SINGLES
#68-0156	INTAKE VALVE	(V226)	BSA A65 UNIT TWINS, THRU 1965
#68-0665	INTAKE VALVE	(V253)	BSA A65 UNIT TWINS, 1966 - 1972
#06-4034	INTAKE VALVE	(V263)	NORTON COMMANDO MODELS

EXHAUST VALVES

PART NO.	DESCRIPTION	MFG#	APPLICATION
#70-6854	EXHAUST VALVE	(V266)	TRI 500 UNIT TWINS
#70-3927	EXHAUST VALVE	(V138)	TRI 650 TWINS, 1958 - 1963
#70-2904	EXHAUST VALVE	(V24)	TRI 650/750 UNIT TWINS
#70-6423	EXHAUST VALVE	(V271)	TRI/BSA 3 CYL MODELS TO 1973
#71-3362	EXHAUST VALVE	(V283)	TRI 3 CYL MODELS, 1973 - 1975
#70-7777	EXHAUST VALVE	(V256)	BSA/TRI 250 SINGLES/ BSA A50 TWINS
#41-0789	EXHAUST VALVE	(V269)	BSA B44, SINGLES
#71-1736	EXHAUST VALVE	(V273)	BSA B50, SINGLES
#68-0663	EXHAUST VALVE	(V254)	BSA A65 UNIT TWINS, THRU 1972
#06-5115	EXHAUST VALVE	(V264)	NORTON COMMANDO MODELS

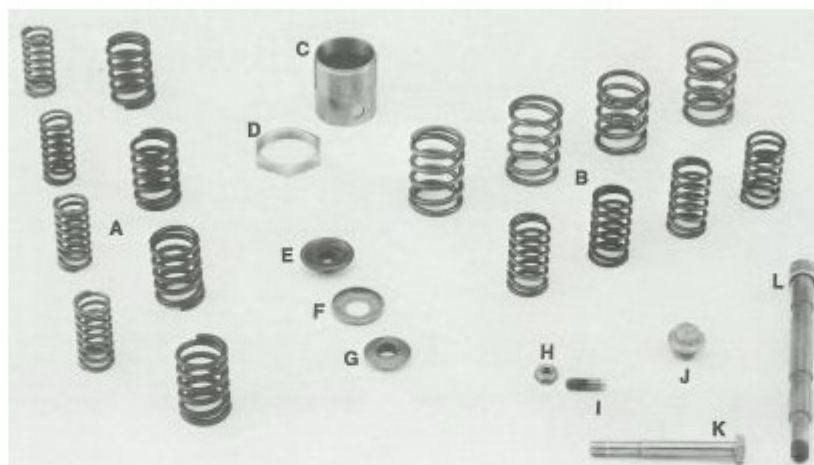

**VALVE SPRINGS, ROCKER BOX HARDWARE, MISC.
ENGINE PARTS**

- | | | |
|---|--|--|
| <p>A) #70-40115 Valve Spring Set (4 Pairs)
TRI 500 Unit Twins - All</p> <p>B) #70-42215 Valve Spring Set (4 Pairs)
TRI 650 1966-'72
TRI 750 Twins 1973 & later</p> <p>C) #70-9510 Exhaust Pipe Adaptor
Supersedes #70-2961
TRI 500 Unit Twins thru 1971</p> <p>#70-9516 Exhaust Pipe Adaptor
Supersedes #70-3583 & #70-5914
TRI 650 Twins thru 1971</p> <p>D) #21-1932 Inlet Manifold Lock Nut
TRI 650 Bonneville Only 1970 -'72</p> | <p>E) #70-1543 Valve Spring Collar (Upper)
Supersedes #40-0171
TRI 650/750 Unit Twins - All
BSA 441 thru 1970</p> <p>F) #70-6855 Valve Spring Cup (Lower)
TRI 500 Unit Twins 1967 & later</p> <p>G) #70-3742 Valve Spring Collar (Upper)
TRI 500 Unit Twins-All</p> <p>H) #60-4264 Rocker Adjustment Nut
Supersedes #GS-662
(Use with #70-3223 Pin)
TRI 500 Unit Twins-All
TRI 200 Cub - All</p> | <p>I) #70-3223 Rocker Adjustment Pin
(Use with #60-4264 Nut)
TRI 500 Unit Twins-All
TRI 200 Cub-All</p> <p>J) #71-2079 Rocker Box Plug
TRI 500 Unit Twins 1971-74
TRI 650 Unit Twins 1971-72</p> <p>K) #70-3809 Rocker Arm Feed Bolt
TRI 500 Unit Twins - All</p> <p>L) #70-1512 Rocker Arm Spindle
TRI 650 Unit Twins thru 1972</p> |
|---|--|--|

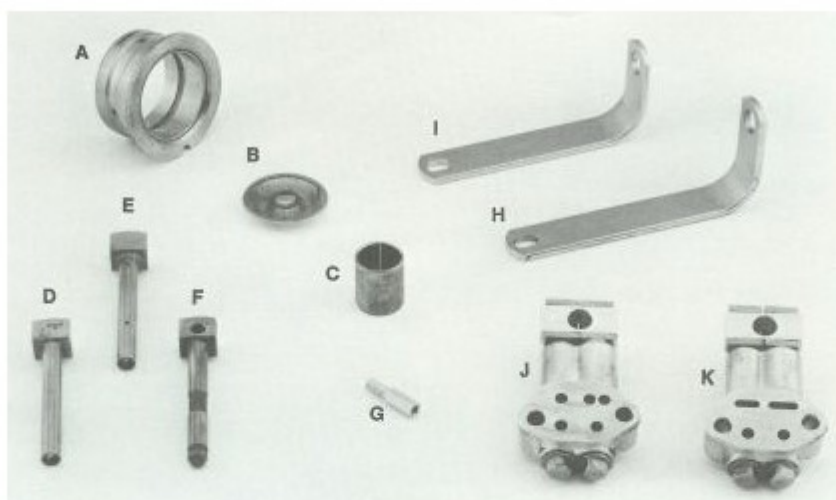

OIL PUMPS, TAPPETS, BUSHINGS, MISC. ENGINE PARTS

- A) #70-4322 Main Bush**
Crankshaft Timing Side
TRI 500 Unit Twins thru 1968
STD/010/020/030
PLEASE SPECIFY SIZE
- B) #70-3722 Sump Filter Screen**
TRI 500 Unit Twins - All
- C) #70-4003 Bushing, Piston Pin**
TRI 500 Unit Twins thru 1969
- D) #70-4040 Tappet "R" Radius**
TRI 500 Unit Twins - All
- E) #70-3753 Tappet**
TRI 350/500 Unit Twins
(Not "R" Radius)
- F) #70-3059R Inlet Tappet**
"R" Radius
TRI 650 Unit Twins - All
- #70-8801 Exhaust Tappet**
"R" Radius
TRI 650/750 Unit Twins, 1967 and later
- G) #70-4747 Pillar Bolt**
for Point Plate
Supersedes #40-0683
TRI/BSA 250 - All
BSA 441 thru 1970
BSA (B50) 500 1971-'73
TRI 500/650 Twins thru 1967
- H) #70-7641 Exhaust Pipe Stay**
(LH) Long
TRI 500 Unit Twins (except TR5T) 1968-'74
- I) #70-7642 Exhaust Pipe Stay**
(RH) Short
TRI 500 Unit Twins (except TR5T) 1968-'74
- #70-6857 Exhaust Pipe Stay**
TRI 650/750 Twins, 1967 and later
- J) #70-6928 Oil Pump**
Supersedes #70-3878
TRI 500 Unit Twins - All
TRI 650 Unit Twins - thru 1969
- K) #70-9421 Oil Pump**
TRI 650/750 Unit Twins 1970-'78
- #71-7317 Oil Pump**
TRI 750 Unit Twins, 1979 and later

500 PISTONS



PART NO.	MAKE - MODEL	YEAR	COMP RATIO and BORE	REF #	OEM #
1) #JP12111	TRI 500 TWINS TRI 500 T100C	1959-66 1967	9:1 69mm	15123	70-6897
2) #JP12110	TRI 500 TWINS	1967 on	9:1 69mm	18786	70-6884

650-750 TWIN PISTONS



PART NO.	MAKE - MODEL	YEAR	COMP RATIO and BORE	REF #	OEM #
1) #JP12120	TRI 650 TWINS	THRU 1972	9:1 71mm	17844	70-6868 70-9488
2) #JP12140	TRI 750 TWINS	1973 on	8:5.1 76mm	19255	71-3676 71-3687 71-3689
3) #JP12260	BSA 650 A65	THRU 1972	9:1 75mm	19233	68-0484 68-0906

NOTE: PISTON SETS COME COMPLETE WITH RINGS, PINS AND CLIPS, UNLESS OTHERWISE STATED IN PRICE SHEET

750 TRIPLE PISTONS



PART NO.	MAKE - MODEL	YEAR	COMP RATIO and BORE	REF #	OEM #
1) #JP12150	TRI 750 III BSA A75 III	1969 on 1969 on	9:1 67mm	17911 19916	70-9741 70-9763

RING SETS



PART NO.	MAKE - MODEL	YEAR	BORE	REF #	OEM #
#JP13110	TRI 500 TWINS	THRU 1974	69mm	13570	99-3750
#JP13120	TRI 650 TWINS	THRU 1972	71mm	11050	99-3771
#JP13140	TRI 750 TWINS	1973 on	76mm	26490	99-3789
#JP13150	TRI 750 TRIPLES BSA 750 TRIPLES	1969 on 1969 on	67mm	23020	99-3780 00-3466
#JP13260	BSA 650 A65 TWINS	1962-72	75mm	17350	00-3454

NOTE: ALL RINGS SOLD IN SETS ONLY.

PLEASE REFER TO THE PRICE SHEET FOR A MORE COMPLETE LISTING, INCLUDING OTHER MODELS STOCKED AND AVAILABLE OVERSIZES.



ROCKER BOX CAPS

PART NO. #JP19001
DESCRIPTION and APPLICATION
 ROCKER CAPS, FINNED CHROME, SET OF 4
 FITS TRI 500/650 UNIT TWINS
 #71-2744 ROCKER BOX CAP
 Supersedes #70-4610
 FITS TRI 500/650 UNIT TWINS
 Also used as OIL FILL CAP
 TRI/BSA 650 1971-1972



PUSH RODS

PART NO. #70-4008
DESCRIPTION and APPLICATION
 PUSHROD, TRI 500 UNIT TWINS, THRU 1974
 #70-2620 PUSHROD, TRI 650 UNIT TWINS, THRU 1972
 #71-3330 PUSHROD, TRI 750 UNIT TWINS, 1973 ON
 #70-6506 PUSHROD, TRI/BSA 3 CYL. 1969
 #71-3974 PUSHROD, TRI 3 CYL T160, 1975



FINNED EXHAUST CLIPS

PART NO. #70-4947
DESCRIPTION and APPLICATION
 FINNED EXHAUST CLIP, TRI 500, THRU 1971, 1 5/8"
 #71-2466 FINNED EXHAUST CLIP, TRI 500, 1972 ON, 1 1/4"
 #71-0216 FINNED EXHAUST CLIP, TRI 650, THRU 1971, 1 3/4"
 #71-2465 FINNED EXHAUST CLIP, TRI 650/750, 1972 ON, 1 3/8"
 #70-6743 FINNED EXHAUST CLIP, TRI/BSA, 3 CYL, 1 5/8"
 #71-4459 FINNED EXHAUST CLIP, TRI 3 CYL T160 RH ONLY, 1 5/8"
 #42-2848 FINNED EXHAUST CLIP, BSA TWINS, 1 1/2"

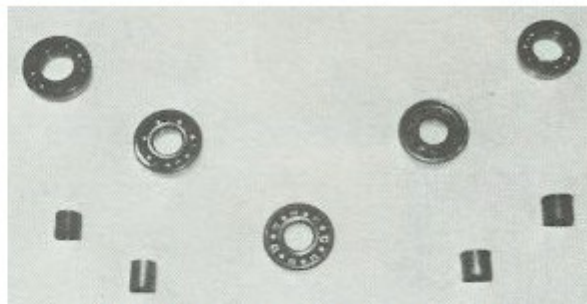

MISC. ENGINE BEARINGS & BUSHINGS

PART NO.	APPLICATION	MAKE - MODELS	YEAR	Super-sedes
#70-1591	CRANK TIMING/BALL CRANK DRIVE/BALL CRANK DRIVE/BALL	TRI 650 TWINS TRI 650 TWINS TRI/BSA 3 CYL	thru 1971 thru 1965 1969 - 75	
#70-2879	CRANK DRIVE/ROLLER	TRI/BSA 650/750 TWINS	1966 on	68-0625
#60-4167	CRANK TIMING/BALL	TRI 650/750 TWINS	1972 on	70-3835
#70-9493	CRANK DRIVE/ROLLER	TRI 500 TWINS	1969 - 74	
#70-9494	CRANK TIMING/BALL	TRI 500 TWINS	1969 - 74	
#06-4118	CRANK DRIVE/ROLLER	NORTON COMMANDO	thru 1975	NM-17824
#57-0448	HIGH GEAR/BALL	TRI/BSA TWINS 4 SPD TRI/BSA 3 CYL 4 SPD	thru 1972 1968 - 72	60-3556
#60-4100	HIGH GEAR/ROLLER	TRI TWINS / 3 CYL 5 SPD	1971 on	
#71-0286	CAM BUSH TIMING SIDE	TRI 650/750 TWINS	All Yrs	70-1479
#71-0287	CAM BUSH DRIVE/EXH CAM BUSH DRIVE/INT	TRI 650/750 TWINS TRI 650/750 TWINS	All Yrs 1970 on	70-1516
#71-0288	CAM BUSH DRIVE/INT	TRI 650 TWINS	thru 1969	70-2260



ROD & MAIN BEARING SETS

- #70-3706 ROD BEARING SET mfg #B2047M
(Supersedes #70-6068, #40-0907)
TRI/BSA 250 SINGLES, 1969 on
TRI 500 TWINS thru 1974
- #70-3586 ROD BEARING SET mfg #B2026M
TRI 650/750 TWINS
- #67-1430 ROD BEARING SET mfg #B2046M
BSA A65/A50 TWINS thru 1972
BSA 650 (A10) 1956 on
- #06-4285 ROD BEARING SET mfg #B2101LC
NORTON 750/850 TWINS thru 1975
- #70-5998 ROD BEARING SET mfg #B3053LC
TRI/BSA 750 TRIPLES thru 1975
- Oversizes - Part #'s 70-9023 - 70-9026
- #70-6023 MAIN BEARING SET mfg #M2098LC
TRI/BSA 750 TRIPLES thru 1975
- Oversizes - Part #70-9027 - #70-9030

NOTE: FOR AVAILABLE OVERSIZES, AND ADDITIONAL LISTINGS, PLEASE REFER TO THE PRICE SHEET



OIL FILTERS

- | PART NO. | DESCRIPTION and APPLICATION |
|-----------------|---|
| #70-6571 | OIL FILTER, TRI/BSA 3 CYLINDER MODELS, 1969 ON |
| #99-1179 | OIL FILTER, BSA/TRI 250, 1971 ON
(Supersedes #19-4590, #82-8903) |
| #06-3371 | OIL FILTER, SPIN-ON, NORTON COMMANDO MODELS |

OIL SUMP SCREENS

- | PART NO. | DESCRIPTION and APPLICATION |
|-----------------|---|
| #70-5312 | OIL SUMP SCREEN, TRI 650 UNIT TWINS, THRU 1967 |
| #70-9336 | OIL SUMP SCREEN, TRI 650/750 TWINS, 1968 ON |
| #71-1126 | OIL SUMP SCREEN
BSA 500/650 (A50/A65) TWINS THRU 1972
BSA 650 A10 TWINS THRU 1962 |
| #70-9979 | OIL SUMP SCREEN, BSA/TRI SINGLES, THRU 1973 |

OIL TANK & FRAME SCREENS

- | PART NO. | DESCRIPTION and APPLICATION |
|-----------------|---|
| #82-9430 | OIL TANK SCREEN
TRI 650 TWINS, 1960 -1970
TRI 500 UNIT TWINS, 750 TRIPLES, THRU 1974
BSA/TRI SINGLES, THRU 1973
(Supersedes #82-3179) |
| #83-3642 | OIL SUMP SCREEN (FRAME), TRI/BSA 650, 1971-1972
OIL IN FRAME MODELS |
| #84-0027 | OIL SUMP SCREEN (FRAME), TRI 750 TWINS, 1973 ON
OIL IN FRAME MODELS, (LATEST STYLE)
(Supersedes #83-4783) |



EXHAUST PIPES

PART NO.	DESCRIPTION	APPLICATION
# 70-5325/7	EXHAUST PIPES, (PAIR)	TRI 500 THRU 1967
# 70-7637/8	EXHAUST PIPES, (PAIR)	TRI 500 THRU 1968
# 70-9662/3	EXHAUST PIPE SET, WITH CROSS	TRI 500 1969 - 1971
# 71-2628/9	EXHAUST PIPE SET, WITH CROSS	TRI 500 1972 - 1973
# 71-3803/7	EXHAUST PIPE SET, WITH CROSS	TRI 500 1974
# 71-3764/5	EXHAUST PIPE SET	TRI 500 TRST
# 70-5957/8	EXHAUST PIPES, (PAIR)	TRI 650 THRU 1968
# 70-9363/4	EXHAUST PIPE SET, WITH CROSS	TRI 650 1969 - 1971
# 71-2636/7	EXHAUST PIPE SET, WITH CROSS	TRI 650 1972
# 71-3755/8	EXHAUST PIPE SET, WITH CROSS	TRI 750 TWINS THRU 1980
# 71-7507/8	EXHAUST PIPE SET, WITH CROSS	TRI 750 1981 ON
# 70-7597A	EXHAUST PIPE SET, W/MANIFOLD	TRI T150 1969 - 1970
# 70-7597B	EXHAUST PIPE SET, W/MANIFOLD	TRI T150 1971 - 1973
# 70-7597C	EXHAUST PIPE SET, W/MANIFOLD	TRI T150 1974
# 71-44075	EXHAUST PIPE SET, WITH COLLECTOR BOX	TRI T160 1975
# 68-2789/1	EXHAUST PIPES, (PAIR)	BSA TWINS 1966 - 1968
# 70-9127/0	EXHAUST PIPE SET, WITH CROSS	BSA TWINS 1969 - 1970
# 71-2043/5	EXHAUST PIPE SET, WITH CROSS	BSA A65 1971 - 1972
# 71-1157A	EXHAUST PIPE SET, W/MANIFOLD	BSA A75 1969 - 1970
# 71-1157B	EXHAUST PIPE SET, W/MANIFOLD	BSA A75 1971 - 1972
# 06-3375/6	EXHAUST PIPES, (PAIR)	NORTON 750 COMMANDO
# 06-3997/8	EXHAUST PIPE SET, WITH CROSS	NORTON COMMANDO
# 06-5256/7	EXHAUST PIPE SET, WITH CROSS	NORTON 850 MARK 3
# 70-9888	CROSS-OVER PIPE ONLY	TRI & BSA TWINS

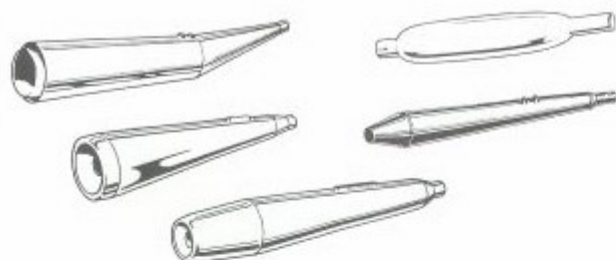

REPLACEMENT MUFFLERS

PART NO.	DESCRIPTION	APPLICATION
#71-2017/8	MUFFLER SET, (PAIR)	TRI 500 TWINS THRU 1973
#70-6974/5	MUFFLER SET, (PAIR)	TRI 500/650 HIGH PIPES 1967 - 1968
#70-9669/0	MUFFLER SET, (PAIR)	TRI 500/650 HIGH PIPES 1969 - 1970
#70-5866	MUFFLER, LH & RH	TRI 650 TWINS THRU 1970
#71-2382	MUFFLER, LH & RH	TRI 650 TWINS & 3 CYL 1971 - 1972
#71-4159	MUFFLER, LH & RH	TRI 750 TWINS 1976 ON
#71-4159J	MUFFLER, LH & RH	TRI 750 TWINS, COPY
#71-4402	MUFFLER, LH & RH	TRI T160, 1975
#70-9654	MUFFLER	BSA VICTOR 1969 - 1970
#68-2732	MUFFLER, LH & RH	BSA A65, A50 TWINS THRU 1970
#71-2382	MUFFLER, LH & RH	BSA TWINS & 3 CYL 1971 - 1972
#06-1978	MUFFLER, LH & RH	NORTON COMMANDO & ROADSTER
#06-4170	MUFFLER, LH & RH	NORTON 850, MARK 3
#70-7512A	CLIP ASSY, WI BOLT & WASHERS, 1 3/8"	
#70-5874A	CLIP ASSY, WI BOLT & WASHERS, 1 1/2"	
#70-2271A	CLIP ASSY, WI BOLT & WASHERS, 1 5/8"	



Pipes for Triumph 650



#JP11631 DRAG PIPES for TRI 650. REPLACEMENT PIPES FIT TRI 650 AND ARE DESIGNED TO BE USED WITH AFTERMARKET MUFFLERS. THEY ARE OF EQUAL LENGTH, FOLLOW THE ORIGINAL CONTOURS AND FEATURE SHOW CHROME FINISH. 1 3/4" DIA.

#JP11632 TT PIPES for TRI 650. "TT" PIPES, EXIT UNDER THE CENTER OF THE BIKE. THEY ARE DESIGNED TO BE USED WITH SILENCER INSERTS, ARE OF EQUAL LENGTH AND FEATURE SHOW CHROME FINISH. 1 3/4" DIA.



#JP11633 SIDE PIPES for TRI 650. SIDE PIPES, CROSS-OVER STYLE, EXIT ON THE RIGHT SIDE OF THE BIKE. THEY ARE DESIGNED TO BE USED WITH SILENCER INSERTS AND FEATURE SHOW CHROME FINISH WITH STRAIGHT CUT ENDS. 1 3/4" DIA.

#JP11620 EXHAUST PIPE ADAPTORS. REDUCER FLANGE PERMITS OUR JP11631, JP11632 AND JP11633 EARLY STYLE TRI 650 PIPES TO BE USED ON LATER MODEL TRI 650/750 TWINS WITH 1 3/8" DIA. PIPES.

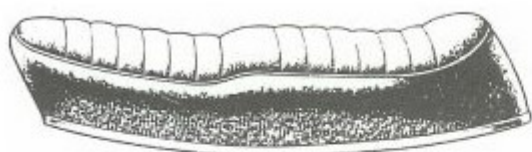

REPLACEMENT SEATS

PART NO.	DESCRIPTION and APPLICATION
#82-5366	SEAT, TRI TWINS, GREY TOP, 1963 - 1966
#82-5366B	SEAT, TRI TWINS, BLACK TOP, 1963 - 1966
#82-9502	SEAT, TRI TWINS, BLACK TOP, 1967 - 1968
#83-1573	SEAT, TRI 650 & 3 CYL, 1969 - 70, TRI 500, 1969 - 74
#83-3634	SEAT, TRI 650, RH HINGE, TACKLE BOX LATCH, 1971 - 1972
#83-4599	SEAT, TRI 650, RH HINGE, PLUNGER LATCH, 1972
#83-7065	SEAT, TRI 750 TWINS, THRU 1977
#83-7127	SEAT, TRI T140, DROP SIDE, BLACK
#83-7391	SEAT, TRI T140, STEPPED
#83-2039	SEAT, TRI 3 CYL T150, 1971 - 1974
#83-5309	SEAT, TRI 3 CYL T160, 1975
#68-9024	SEAT, BSA TWINS, FLAT STYLE, 1962 - 1966
#68-9330	SEAT, BSA TWINS, WITH HUMP, 1967 - 1970
#83-3633	SEAT, BSA 650, 1971 - 1972
#82-8942	SEAT, BSA ROCKET 3, 1969 - 1970
#83-3853	SEAT, BSA ROCKET 3, 1971-1972
#06-1766	SEAT, NORTON ROADSTER, 1969 - 1971, WITH STRAP
#06-3676	SEAT, NORTON ROADSTER, 1971 - 1973
#06-3677	SEAT, NORTON INTERSTATE, 1971 - 1973
#06-5612	SEAT, NORTON ROADSTER, MK 3
#06-5613	SEAT, NORTON INTERSTATE, MK 3

**NOTE: PLEASE REFER TO THE PRICE SHEET FOR
ADDITIONAL SEAT AND COVER LISTINGS**



SEAT COVERS

PART NO.	DESCRIPTION and APPLICATION
#82-5418	COVER, TRI TWINS, GREY TOP, 1963 - 1966
#82-5418B	COVER, TRI TWINS, BLACK TOP, 1963 - 1966
#82-7489	COVER, TRI TWINS, BLACK TOP, 1967 - 1968
#82-9715	COVER, TRI 650 & 3 CYL, 1969 - 70 TRI 500, 1969 - 74
#83-3637	COVER, TRI 650, WIDE FRONT, 1971 - 1972
#83-4291	COVER, TRI 650, NARROW FRONT, 1972
#83 7066	COVER, TRI 750, TWINS, THRU 1977
#83-7131	COVER, TRI T140 DROP SIDE, BLACK
#83-7793	COVER, TRI T140 STEPPED, BLACK
#83-2239	COVER, TRI 3 CYL T150, 1971 - 1974
#83-5378	COVER, TRI 3 CYL T160, 1975
#68-9024C	COVER, BSA TWINS, FLAT STYLE, 1962 - 1966
#68-9330C	COVER, BSA TWINS, WITH HUMP, 1967 - 1970
#83-4290	COVER, BSA 650, 1971 - 1972
#06-1766C	COVER, NORTON ROADSTER, 1969 - 1971
#06-3676C	COVER, NORTON ROADSTER, 1971 - 1975
#06-3677C	COVER, NORTON INTERSTATE, 1971 - 1975



SIDE COVERS & BODY PANELS

PART NO.	DESCRIPTION & APPLICATION
#83-1358	SIDE COVER, LH, TRI 650, 1968 - 70, TRI 500, 1968 - 74
#83-4906	SIDE COVER, LH STEEL, TRI 500, TR5T 1973
#83-3851	SIDE COVER, FILTER BOX RH, TRI T120, 1971 - 1972
#83-4807	SIDE COVER, FILTER BOX LH, TRI TR7, 1973 ON
#83-4808	SIDE COVER, FILTER BOX RH, TRI TR7, 1973 ON
#83-7067	SIDE COVER, FILTER BOX LH, TRI T140, 1973 ON
#83-7068	SIDE COVER, FILTER BOX RH, TRI T140, 1973 ON
#83-4673	SIDE PANEL, REAR, LH STEEL, TRI/BSA 650, 1971 - 1972
#83-4675	SIDE PANEL, REAR, RH STEEL, TRI/BSA 650, 1971 - 1972
#83-4854	SIDE PANEL, REAR, LH STEEL, TRI T140 THRU 1978
#83-4803	SIDE PANEL, REAR, RH STEEL, TRI T140 THRU 1978
#83-8428	SIDE COVER, OUTER, LH BLACK, TRI TSX
#83-8429	SIDE COVER, OUTER, RH BLACK, TRI TSX
#82-9362	SIDE COVER, LH, TRIDENT 1969 - 1970
#82-9363	SIDE COVER, RH, TRIDENT 1969 -1970
#83-4856	SIDE COVER, LH, TRIDENT T150, 1971 ON
#83-4857	SIDE COVER, RH, TRIDENT T150, 1971 ON
#83-5690	SIDE COVER, LH, STEEL, TRIDENT T160
#82-9805	SIDE COVER, LH, BSA A65 TWIN CARB, BLACK
#82-9806	SIDE COVER, RH, BSA A65 TWIN CARB, BLACK
#82-9805R	SIDE COVER, LH, BSA A65 TWIN CARB, RED
#82-9806R	SIDE COVER, RH, BSA A65 TWIN CARB, RED

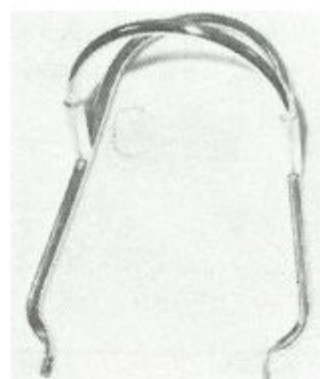

REAR HANDRAILS

PART NO.	DESCRIPTION & APPLICATION
#83-1571	HANDRAIL, REAR TRI 500/650 TWINS, 1970
#83-2768	HANDRAIL, REAR TRI/BSA 650 TWINS, 1971 - 1972
#83-5145	HANDRAIL, REAR TRI 750 TWINS, 1973 - 1978
#83-7547	HANDRAIL, W/RACK, TRI 750 TWINS, 1979 ON
#82-9356	HANDRAIL, REAR TRIDENT, 1969
#83-2879	HANDRAIL, REAR TRI 500 & T150 3 CYL 1971 - 1973
#83-5147	HANDRAIL, REAR TRI 500 & T150 3 CYL 1974 ON
#83-3486	HANDRAIL, REAR X75 HURRICANE
#41-9152	HANDRAIL, REAR BSA SINGLES, THRU 1970
#68-9327	HANDRAIL, REAR BSA TWINS, THRU 1970
#82-8485	HANDRAIL, REAR BSA ROCKET 3, 1969 - 1970
#83-3443	HANDRAIL, REAR BSA ROCKET 3, 1971 - 1972
#06-3819	HANDRAIL, REAR NORTON COMMANDO
#06-3632	HANDRAIL, REAR NORTON INTERSTATE



RUBBERS

FOOT PEG, KICKSTART, GEAR SHIFT

- | PART NO. | DESCRIPTION & APPLICATION |
|-----------------|---|
| #82-9279 | FOOTPEG RUBBER, FRONT, WITH "TRIUMPH" NAME |
| #82-9630 | FOOTPEG RUBBER, FRONT, WITH "TRIUMPH" NAME, TRIDENT |
| #83-7256 | FOOTPEG RUBBER, FRONT LH, TRI 750 1979 ON |
| #83-7259 | FOOTPEG RUBBER, FRONT RH, TRI 750 1979 ON |
| #82-1695 | FOOTPEG RUBBER, PILLION, WITH "TRIUMPH" NAME, EARLY |
| #82-9054 | FOOTPEG RUBBER, PILLION, BSA & LATE TRI |
| #82-9602 | FOOTPEG RUBBER, FRONT, WITH "BSA" NAME, THRU 1970 |
| #82-9608 | FOOTPEG RUBBER, FRONT, FOLD-UP WITH "BSA" NAME |
| #82-9051 | FOOTPEG RUBBER, FRONT, FOLD-UP, BSA PLAIN |
| #83-2651 | FOOTPEG RUBBER, FRONT, WITH "BSA" 1971 - 1972, 650 |
| #29-7551 | FOOTPEG RUBBER, FRONT, OVAL EARLY BSA |
| #82-9603 | FOOTPEG RUBBER, PILLION, WITH "BSA" NAME |
| #06-7760 | FOOTPEG RUBBER, FRONT, NORTON COMMANDO |
| #04-2569 | FOOTPEG RUBBER, PILLION, NORTON |
| #57-2330 | KICK RUBBER, TRI/BSA MOST MODELS |
| #57-2450 | SHIFT RUBBER, TRI/BSA MODELS, OVAL |
| #57-2331 | CENTER STAND/SHIFT RUBBER, OPEN END |
| #03-3218 | KICK RUBBER, NORTON |
| #04-0086 | SHIFT RUBBER, NORTON |



FOOTRESTS

- | PART NO. | DESCRIPTION & APPLICATION |
|-----------------|--|
| #82-4215 | FOOTREST, RH, TRI 500 TWINS |
| #83-1590 | FOOTREST ASSY, LH FOLDING, TRI 500 TWINS |
| #83-1591 | FOOTREST ASSY, RH FOLDING, TRI 500 TWINS |
| #83-7040 | FOOTREST, LH & RH TRI 650/750 TWINS, 1971 ON |
| #06-2734 | FOOTPEG, FRONT, NORTON COMMANDO |
| #06-5407 | FOOTPEG, FRONT, NORTON 850 MK 3 |
| #82-9369 | FOOTREST ASSY, PILLION, TRI EARLY STYLE |
| #83-7695 | FOOTREST ASSY, PILLION, TRI 750 TWINS |





SWING ARM BUSHINGS & SPINDLES

PART NO.	DESCRIPTION and APPLICATION
#82-3690	SWING ARM BUSH, TRI PRE-UNIT TWINS
#83-2521	SWING ARM BUSH, TRI/BSA OIL FRAME TWINS, 1971 ON
#82-8475	SWING ARM BUSH, BSA 3 CYL
#06-0447	SWING ARM BUSH, NORTON COMMANDO 750
#82-7342	SWING ARM SPINDLE, TRI 500 UNIT TWINS, 1967 - 1974
#82-6821	SWING ARM BOBBIN, TRI 650 UNIT TWINS, THRU 1970
#83-2691	SWING ARM SLEEVE, TRI/BSA OIL FRAME TWINS, 1971 ON
#83-3554	SWING ARM SPINDLE, BSA SINGLES, TR5T 1971 ON
#06-0453L	SWING ARM SPINDLE, NORTON COMMANDO 750



SIDE STANDS

PART NO.	DESCRIPTION and APPLICATION
#82-7356	SIDE STAND, TRI TWINS, THRU 1967
#83-1560	SIDE STAND, TRI/BSA TWINS, TRIPLES



CHAIN GUARDS

PART NO.	DESCRIPTION and APPLICATION
#83-2641	CHAIN GUARD, TRI 650/750 TWINS, 1971 ON
#3P46000	CHAIN GUARD, CHROME UNIVERSAL, W/ BRACKETS



SEAT HINGES

PART NO.	DESCRIPTION and APPLICATION
#82-4222	SEAT HINGE, "J" STYLE, EARLY TRI
#83-4782	SEAT HINGE, TRI 750 TWINS
#83-7542	SEAT HINGE, REAR, TRI T140, 1982 ON

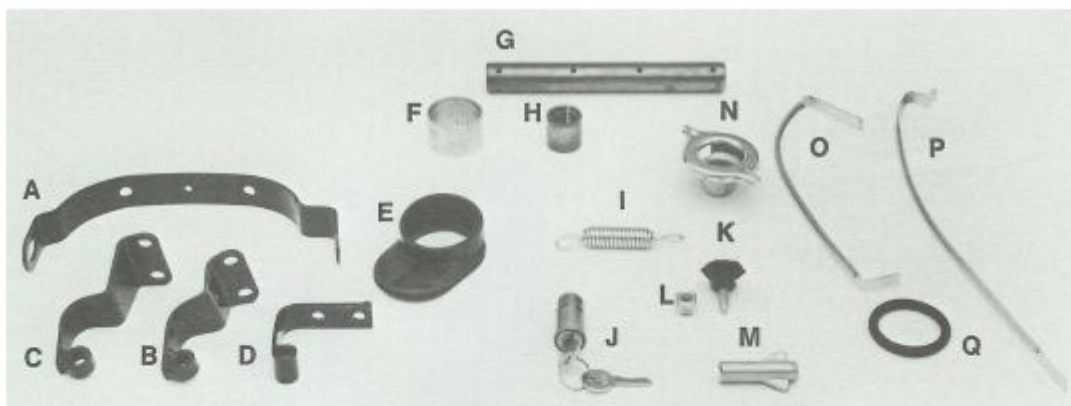

SWING ARM, FRAME, FUEL TANK HARDWARE, MISC.

- | | | |
|--|--|---|
| <p>A) #82-6915 Rear Fender Bracket
TRI 500 (except TR5T) thru 1974
TRI 650 thru 1970
TRIDENT 750 - All</p> <p>B) #82-7862 Seat Hinge (Rear)</p> <p>C) #82-8026 Seat Hinge (Front)
TRI 500 (except TR5T) 1968-'74
TRI 650 1968 - '70
TRIDENT 750 - All</p> <p>D) #83-2867 Seat Hinge (Front/Rear)
TRI/BSA 650 1971 - '72</p> <p>E) #83-2625 Carburetor Connector Pipe
(Single Carb Models Only)
TRI/BSA 650 1971 - '72</p> <p>F) #82-6042 Swing Arm Bushing
BSA 650 1969 - '70
TRI 650 1963 - '70
TRIDENT 750 - All</p> | <p>G) #82-4195 Swing Arm Spindle
TRI 500 Unit Twins thru 1966</p> <p>H) #82-4076 Swing Arm Bushing
TRI 500 (except TR5T) Unit Twins thru 1974</p> <p>I) #82-8382 Spring - Side Stand
TRI 500 (except TR5T) 1969 - '74
TRI/BSA 650/750 Unit Twins 1968 & later
TRIDENT/BSA 3 Cylinder - All</p> <p>J) #82-6738 Steering Lock & Keys
Supersedes #68-5050
Also Norton #03-0175
TRI/BSA 500/650/750 Twins 1967 & later
TRIDENT/BSA 3 Cylinder - All
NORTON 750/850 - Most</p> <p>K) #83-1357 Panel Knob
Supersedes #82-8044</p> | <p>L) #83-0222 Nut for Panel Knob
Supersedes #82-1022
TRI 500 (except TR5T) 1968 - '74
TRI 650 1968 - '70</p> <p>M) #82-7387 Brake Adjuster Wing Nut
TRI/BSA - All later models
(28 Threads Per Inch)</p> <p>N) #83-3318 Holder for Fuel Tank Trim
Supersedes #68-8035
TRI 650 1971 - '72
BSA 650 thru 1970
BSA (A75) 750 1971</p> <p>O) #83-3134 Fuel Tank Trim (Front)</p> <p>P) #83-3135 Fuel Tank Trim (Rear)
TRI 650 1971 - '72</p> <p>Q) #83-3321 "O" Ring for #83-3318 Holder
TRI 650 1971 - '72</p> |
|--|--|---|



FUEL TANK BADGES

PART NO.	DESCRIPTION and APPLICATION	OEM#
#JP72101	BADGE SET, FUEL TANK, TRI TWINS, 1966-1968	PAIR 82-6887/8
#JP72102	BADGE SET, FUEL TANK, TRI TWINS & 3 CYL 1969 ON	PAIR 82-9700/1
#JP72104	BADGE, FUEL TANK, TRI T140 UK STYLE, SCRIPT	60-2569 60-7210 60-7303
#JP72107	BADGE SET, FUEL TANK, TRIDENT 1969-1970	PAIR 82-9360/1



#JP72201	BADGE SET, FUEL TANK, BSA TEARDROP, BLACK	PAIR 40-8014/5
#JP72202	BADGE SET, FUEL TANK, BSA TEARDROP, RED	PAIR 40-8122/3
#JP72209	BADGE SET, FUEL TANK, BSA TEARDROP, METAL PLAIN	PAIR 82-9695/6
#JP72211	BADGE, FUEL TANK, BSA TWINS, 1971-1972	60-2568



FUEL TANK BADGES

PART NO.	DESCRIPTION and APPLICATION	OEM#
#JP72203	BADGE, FUEL TANK, BSA PILED ARMS, 3 1/4"	65-8220
#JP72204	BADGE, FUEL TANK, BSA OATMEAL, 3 1/4"	41-8004
#JP72205	BADGE, FUEL TANK, BSA BLACK, GOLDSTAR, 4"	68-8087
#JP72206	BADGE, FUEL TANK, BSA RED, GOLDSTAR, 4"	65-8193 65-8228
#JP72207	BADGE SET, FUEL TANK, BSA RCKT 3, 1969-1970	PAIR 82-8610/1



#JP72301	BADGE, FUEL TANK, NORTON ROUND, 3 1/4"
----------	--

GROMMET BADGES

PART NO.	DESCRIPTION and APPLICATION
#83-4776	BADGE, TANK GROMMET, TRI 750, GOLD ON SILVER
#83-8656	BADGE, TANK GROMMET, TRI 750, GOLD ON BLACK
#97-5061	GROMMET FOR FUEL TANK BADGES, TRI 750 TWINS

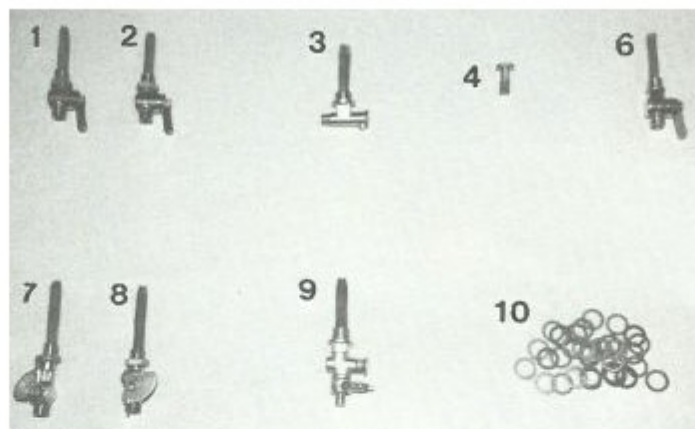

FUEL PETCOCKS & PARTS

- 1) **#PT131 PETCOCK - Reserve**
 1/4 x 1/4 With Lock Nut
 (Supersedes #03-1746, #06-5999,
 #83-2800)
 TRI/NORTON Most models thru 1974
 BSA 1971 on
- 2) **#PT132 PETCOCK - Normal**
 1/4 x 1/4 With Lock Nut and Stand Tube
 (Supersedes #03-3155, #06-5998,
 #83-2801)
 TRI/NORTON Most models thru 1974
 BSA 1971 on
- 3) **#PT121 PETCOCK**
 90° Plunger Type,
 with Filter 3/8 x 7/16
 (Supersedes #68-8024, #82-9611)
 BSA 500/650 TWINS thru 1970
- 4) **#PTS102 PLUNGER**
 Replacement for all Push/Pull
 Plunger Type Petcocks
- 6) **#PT131J PETCOCK**
 1/4 x 1/4 With Lock Nut
 Economy Replacement for PT131
- 7) **#PT136 PETCOCK - Reserve**
 1/4 x 1/4 With Nameplate & Lock Nut
 (Supersedes #60-4512)
 TRI/NORTON 1975 & later
- 8) **#PT137 PETCOCK - Normal**
 1/4 x 1/4 With Nameplate,
 Lock Nut and Stand Tube
 (Supersedes #60-4511)
 TRI/NORTON 1975 & Later
#PT7266 PETCOCK - Normal
 (not illustrated)
 (Supersedes #60-7266)
 TRI Late Style Diecast, 1979 - 1981
#PT7267 PETCOCK - Reserve
 (not illustrated)
 (Supersedes #60-7267)
 TRI Late Style Diecast, 1979 - 1981
- 9) **#PT61 PETCOCK**
 Plunger Type, with Filter
 3/8 With Banjo Fitting
 (Supersedes #42-8075)
 BSA Twins thru 1968
- 10) **#PTW14 FIBRE WASHER**
 for 1/4 Triumph Style Petcocks
#PTW38 FIBRE WASHER
 for 3/8 PT121 BSA Style Petcocks
#70-7351 SEALING WASHER
 (not illustrated)
 Steel Washer with Rubber Insert
 for 1/4 Triumph Style Petcocks
#FLPC CLEAR FUEL LINE
 (not illustrated)
 1/4 x 1/2 Sold by the Foot
#83-3875 FUEL TANK CAP
 (not illustrated)
 (Supersedes #82-3220, #82-9226,
 #29-7898, #75-8009)
 Fits Most TRI Models, Many BSA



FUEL TANK KNEE PADS

PART NO.	DESCRIPTION and APPLICATION
#82-5401/2	KNEE PADS, PAIR, TRI TWINS 1963 - 1967
#82-8192/3	KNEE PADS, PAIR, TRI TWINS 1968 ON
#83-4355/6	KNEE PADS, PAIR, T140 UK STYLE TANK
#40-8029/0	KNEE PADS, PAIR, BSA, EARLY TWINS
#82-9722/3	KNEE PADS, PAIR, BSA, SINGLES



HANDLEBARS & GRIPS

PART NO.	DESCRIPTION and APPLICATION
#97-4252	HANDLEBAR, TRI TWINS THRU 1972
#97-7001	HANDLEBAR, TRI 750 TWINS, USA
#97-7040	HANDLEBAR, TRI 750 TWINS, USA 1979 ON
#97-4583	HANDLEBAR, TRI TWINS & TRIPLES, UK MODELS
#97-4651	HANDLEBAR, TRI 3 CYL, T160
#97-4062	HANDLEBAR, WITH BRACE, BSA SINGLES, TRI TR5T
#97-2628	HANDLEBAR, BSA SINGLES & 3 CYL MODELS
#65-4960	HANDLEBAR, BSA A10, UK MODELS
#06-1046	HANDLEBAR, NORTON COMMANDO
#06-4132	HANDLEBAR, NORTON COMMANDO, EUROPEAN
#97-2124J	HAND GRIPS, PAIR, "GT" TYPE, COPY, TRI/BSA/NOR



FRONT FENDERS

PART NO.	DESCRIPTION	APPLICATION
#97-4270	FRONT FENDER CHROME, WITH WIRE STAYS	TRI/BSA 1971 - 1972
#68-6536	FRONT FENDER, CHROME, 6 TAB	BSA A65 THRU 1970
#06-6204	FRONT FENDER, STAINLESS	NORTON COMMANDO MK3
#JP40041	FRONT FENDER, BARE 4"	UNDRILLED
#JP40042	FRONT FENDER, STAINLESS 4"	UNDRILLED
#JP40043	FRONT FENDER, CHROME 4"	UNDRILLED
#JP40044	FRONT FENDER, CHROME 4"	UNDRILLED, SHORT



REAR FENDERS

PART NO.	DESCRIPTION	APPLICATION
#82-8143	REAR FENDER, BARE UNDRILLED	TRI TWINS THRU 1970
#82-8144	REAR FENDER, STAINLESS UNDRILLED	TRI TWINS THRU 1970
#83-3565	REAR FENDER, CHROME UNDRILLED	TRI/BSA 650 1971 - 1972
#83-7031	REAR FENDER, CHROME	TRI 750 TWINS 1976 - 1978



SHOCKS, SPRINGS, MISC.

PART NO.	DESCRIPTION and APPLICATION
#JP43020	SHOCK ASSY, 12.9" WITH SPRINGS, PAIR TRI 500/650 TWINS
#JP43024	SHOCK ASSY, 12.4" WITH SPRINGS, PAIR TRI 750 TWINS
#JP43022	SHOCK ASSY, 13.4" WITH SPRINGS, PAIR BSA TWINS, THRU 1970

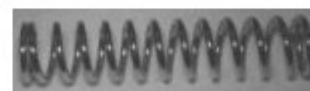

PART NO.	DESCRIPTION and APPLICATION
#64532778	DIRT SHIELD, REAR SHOCK, CHROME
#64533025	DIRT SHIELD, REAR SHOCK, UPPER BLACK, 5"
#64543708	SPRING, CHROME 100 LB x 9", GIRLING STYLE SHOCK
#64544754	SPRING, CHROME 110 LB x 9", GIRLING STYLE SHOCK
#64533645	BONDED BUSH, GIRLING SHOCK MOUNT

FENDER STAYS, MISC.



- 1) **#97-1681 FENDER STAY (Black)**
Front - TRI 250 1970
TRI 500 1964 - 1972
TRI 650 1966 - 1970
TRI 750 TRIDENT 1969
- 2) **#97-1683 FENDER STAY (Black)**
Center, Fits Same Applications as Above
- 3) **#97-3885 FENDER STAY (Black)**
Back (Supersedes #97-4044)
Fits Same Applications as Above
- 4) **#97-3663 FENDER STAY (Chrome)**
Front - TRI 500 1969 - 1974
TRI 650 1969 - 1970
TRI 750 TRIDENT 1970
- 5) **#97-3664 FENDER STAY (Chrome)**
Center, Fits Same Applications as Above
- 6) **#97-3886 FENDER STAY (Chrome)**
Back, Fits Same Applications as Above

- 1) **#97-4552 FENDER STAY, Bottom Chrome**, (Supersedes #97-4535, #97-4447)
TRI 750 TWINS & TRIPLES 1973 on
- 2) **#97-3688 FENDER STAY, Bottom Chrome**
For One Bolt Mount Systems
TRI 500/650 TWINS Thru 1969
- #97-1678 FENDER STAY**
As Above, Except Black Finish

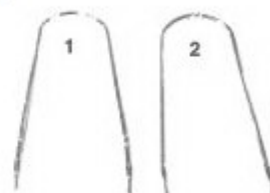

- #97-1685 FENDER STAY BRACKET**
TRI 250 1970
TRI 500 1964 - 1974
TRI 650 1964 - 1970
TRI 750 TRIDENT 1968 - 1970



- #97-2237 HEAT SINK**
For Zener Diode
Fits TRI Singles & Twins 1968 -1970
TRI/BSA Triples 1969 - 1975



- #97-2275 HEAT SINK PLUG**
Fits Heat Sink Listed Above



STEERING BEARINGS & FORK HARDWARE

- | PART NO. | DESCRIPTION and APPLICATION |
|-----------------|--|
| #97-0439 | STEERING RACE, STEM, TRI TWINS, 3 CYL, EARLY |
| #97-0111 | STEERING RACE, FRAME, TRI TWINS, 3 CYL, EARLY |
| #97-1018 | STEERING RACE & COVER, TRI TWINS, 3 CYL, EARLY |
| #JPS1020 | STEERING RACE KIT, TRI TWINS, 3 CYL, EARLY, SET OF 4 |
| #JPS1030 | STEERING RACE KIT, TAPERED ROLLER CONVERSION EARLY TRI |
| #97-1110 | STEERING RACE, STEM, TRI 500, 1957-1966 |
| #97-1130 | STEERING RACE, FRAME, TRI 500, 1957-1966 |
| #97-1140 | STEERING RACE & COVER, TRI 500, 1957-1966 |
| #JPS1010 | STEERING RACE KIT, BSA TWINS, THRU 1970, SET OF 4 |
| #JPS1011 | STEERING RACE KIT, BSA SINGLES, THRU 1970, SET OF 4 |
| #60-2364 | STEEL BALLS, 1/4" DIAMETER, PACK OF 22 |
| #06-7604 | STEERING STEM BEARING, NORTON COMMANDO |
| #97-1844 | FRONT AXLE CAP, TRI, THRU 1970 |
| #97-3947 | FRONT AXLE CAP, TRI/BSA 650/750, 1971-1972 |
| #97-4456 | FRONT AXLE CAP, LH, TRI DISC BRAKE MODELS |
| #97-4457 | FRONT AXLE CAP, RH, TRI DISC BRAKE MODELS |

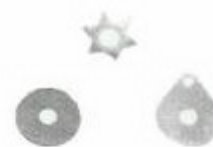

STEERING DAMPER MISC

- | PART NO. | DESCRIPTION and APPLICATION |
|-----------------|---|
| #97-0405 | NUT, STEERING STEM CENTER, TRI TWINS THRU 1966 |
| #97-2108 | NUT, STEERING STEM CENTER, TRI TWINS, 1967-1970 |
| #97-0408 | BOTTOM NUT, STEERING DAMPER, TRI TWINS |
| #97-0095 | SPRING PLATE, STEERING DAMPER, TRI TWINS |
| #97-0435 | FRICTION DISC, STEERING DAMPER, TRI TWINS |
| #97-1797 | BOTTOM PLATE, STEERING DAMPER, TRI TWINS |



FORK CAP NUTS

- | PART NO. | DESCRIPTION and APPLICATION |
|-----------------|--|
| #97-1658 | FORK CAP NUT, CHROME, 26 TPI, TRI, THRU EARLY 1968 |
| #97-2245 | FORK CAP NUT, CHROME, 28 TPI, TRI/BSA, 1968-1970 |
| #97-4309 | FORK CAP NUT, TRI/BSA 650/750, 1971-1972 |
| #97-4387 | FORK CAP SCREW, TRI 750, TWINS, 3 CYL, 1973 ON |
| #97-4395 | FORK CAP TOP NUT, TRI 750, TWINS, 3 CYL, 1973 ON |
| #65-5331 | FORK CAP NUT, CHROME, BSA EARLY |
| #06-0345 | FORK CAP NUT, CHROME, NORTON COMMANDO |

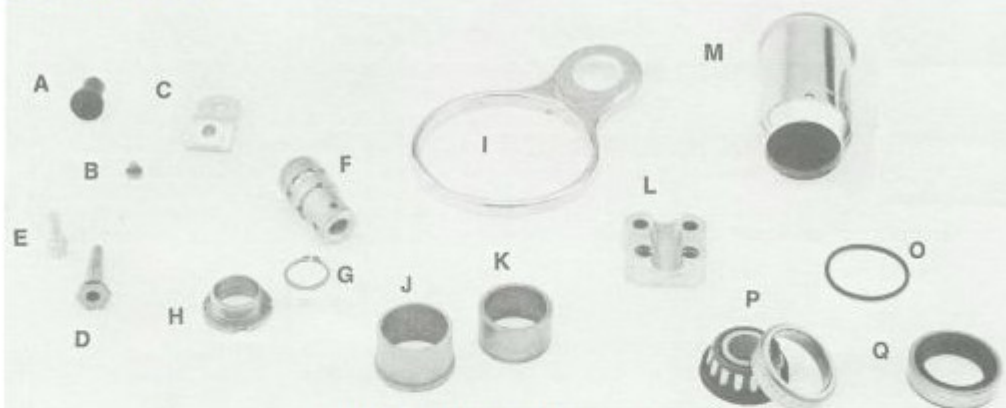

FORK HARDWARE, BUSHINGS, SEALS

A) #97-4021 Fender Mount Bushing

TRI/BSA 250 1971
BSA 500 (B50) 1971-72
TRI/BSA 650 1971-72
TRIDENT/BSA (A75) 750 1971-73

B) #97-0519 Fork Drain Plug

(With Hex Head)
Fits most TRIUMPH early forks

C) #97-4262 Bracket for Heat Sink

Supersedes #97-2236 & #97-2365
TRI 500 1968-74
TRI 650 1968-70
TRIDENT/BSA (A75) 750 1969-70

D) #97-2090 Damping Restriction (Shuttle Valve)

E) #97-2126 Damping Restrictor Bolt

F) #97-2154 Shuttle Damper Valve

G) #97-2127 Circlip (Secures Shuttle Valve)

H) #97-2091 Nut (Secures Lower Fork Bush)

TRI/BSA 250 1969-70
TRI 500 (except TR5T) 1968-74
TRI 650 1968-70
BSA 650 1969-70
TRIDENT/BSA (A75) 750 1969-70

I) #97-4026 Speedo/Tach Mount Bracket

BSA 250 1971
BSA 500 (B50) 1971-73
TRI/BSA 650/750 Twins 1971-78
TRIDENT/BSA (A75) 750 1971-74

#60-2600 Rubber Boot, Instrument Mount
(not illustrated)

Use with #97-4026 bracket above

J) #97-0441 Fork Bushing Upper

Supersedes #75-5105

K) #97-0443 Fork Bushing Lower

Supersedes #75-5104
TRI/BSA 250 1969-70
TRI 500 (except TR5T) thru 1974
TRI 650 thru 1970
BSA 650 1969-70
TRIDENT/BSA (A75) 750 1969-70

L) #97-3947 Lower Cap - Front Axle

TRI/BSA 250 1971
BSA 500 (B50) & 750 (A75) 1971 on
TRI 500 (TR5T only) 1973-74
TRI/BSA 650 1971-72
TRIDENT 750 1971-72

M) #97-3633 Fork Seal Sleeve Nut (Chrome)

Supersedes #97-1654 & #97-4167
TRI 500 Twins 1964-74
TRI 650 Twins 1964-70
BSA 500/650 Twins 1969-70
TRIDENT/BSA (A75) 750 1969-70

O) #97-2119 "O" Ring for Fork Sleeve Nut

Supersedes #75-5199
Fits #97-3633

P) #97-4031 Steering Bearing (Taper Roller)

TRI/BSA 250 1971
TRI 500 (TR5T Only) 1973-74
TRI/BSA 650/750 Twins 1971 on
BSA 500 (B50) 1971-73
TRIDENT 750 1975

Q) #97-1500 Fork Seal

Supersedes #75-5099
TRI/BSA 250 1969-70
TRI 500 (except TR5T) 1964-74
TRI 650 1964-70
BSA 650 1969-70
TRIDENT/BSA (A75) 750 1969-70



FORK BOOTS, WIPERS, MISC.

PART NO.	DESCRIPTION and APPLICATION
#97-1510	FORK BOOT, TRI T140 & PRE-UNIT MODELS
#97-1645	FORK BOOT, TRI TWINS, 1964 - 1968
#97-3635	FORK BOOT, TRI 650 & 3 CYL, 1969 - 1970 TRI 500 1969 - 1974
#97-4002	FORK WIPER, TRI/BSA, 1971 ON
#42-5320	FORK BOOT, BSA TWINS, THRU 1967
#97-2513	FORK BOOT, BSA SINGLES/TWINS, 1968 - 1970
#06-1115	FORK WIPER, NORTON COMMANDO
#06-5743	FORK BOOT, NORTON COMMANDO
#97-2083	FORK BOOT CLAMP, TRI TWINS, 1967 - 1968
#42-5323	FORK BOOT CLAMP, BSA THRU 1967



FORK SEALS & BUSHINGS

PART NO.	DESCRIPTION and APPLICATION
#97-1168	SEAL, FRONT FORK, TRI PRE-UNIT
#97-1500	SEAL, FRONT FORK, TRI 1964 - 1970
#97-1500J	SEAL, FRONT FORK, Economy Replacement
#97-4001	SEAL, FRONT FORK, TRI/BSA 650/750 1971 ON
#97-4001J	SEAL, FRONT FORK, Economy Replacement
#97-7079	SEAL, FRONT FORK, TRI T140, LATER STYLE
#97-7079J	SEAL, FRONT FORK, Economy Replacement
#97-2641	SEAL, FRONT FORK, BSA THRU 1968
#97-2641J	SEAL, FRONT FORK, Economy Replacement
#06-5483	SEAL, FRONT FORK, NORTON
#97-2637/8	BUSH, FRONT FORK, BSA THRU 1968, SET OF 4
#06-7521	BUSH, FRONT FORK, UPPER NORTON
#06-7519	BUSH, FRONT FORK, LOWER NORTON
#97-1896	FORK DAMPER SLEEVE, TRI TWINS THRU 1970

NOTE: SEALS ENDING IN "J" ARE GOOD QUALITY REPLACEMENT ITEMS MADE TO ORIGINAL SPECIFICATIONS

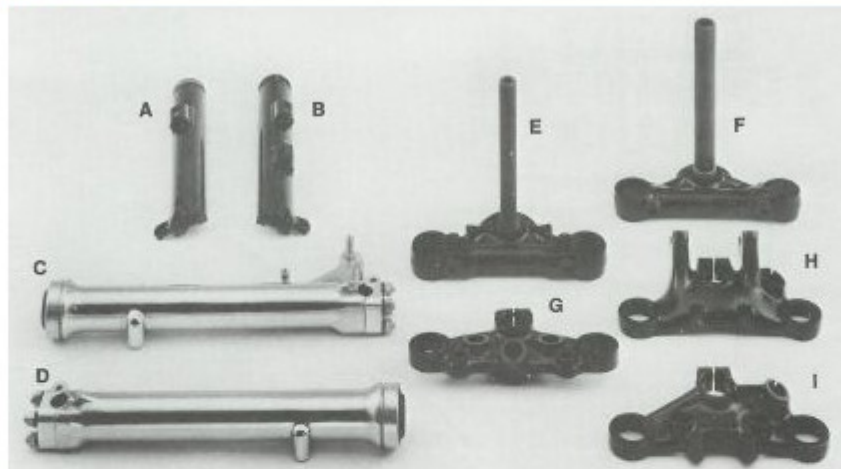

FORK COMPONENTS

- A) #97-4170 Outer Fork Leg (Left Hand)**
Supersedes #97-1842 & #97-2294 & #97-3921
TRI/BSA 250 1969-70
TRI 500 thru 1974
TRI 650 thru 1970
TRIDENT/BSA (A75) 750 1969-70
- B) #97-4220 Outer Fork Leg (Right Hand)**
Supersedes #97-3922
TRI/BSA 250 1970
TRI 500 1970-74
TRI 650 1970
TRIDENT/BSA (A75) 750 1970

- C) #97-7088 Outer Leg (Left Hand)**
Supersedes #97-4377 & #97-4399
TRI 750 Twins 1973 on
TRIDENT 750 1974-75
- D) #97-7089 Outer Leg (Right Hand)**
Supersedes #97-4515 & #97-4579
TRI 750 Twins 1973 on
TRIDENT 750 1974-75
- E) #97-4315 Middle Lug & Stem (Shown)**
Supersedes #97-4082
TRI/BSA 650 Twins 1971-72
#97-4321 Middle Lug & Stem
TRIDENT 750 1972-73
#97-4138 Middle Lug & Stem
BSA (A75) 750 1971-72
TRIDENT 750 1971

- F) #97-2288 Middle Lug & Stem**
TRI 500 T100C & T100R 1969-74
TRI 650 T120R 1969
- G) #97-4035 Top Lug**
Supersedes #97-4084
TRI/BSA 650 Twins 1971-72
TRIDENT/BSA (A75) 750 1971-73
- H) #97-3662 Top Lug**
TRI 500 T100C & T100R 1969-74
TRI 650 TR6C 1969-70
- I) #97-3667 Top Lug (Shown)**
TRI 500 T100S & T100T 1969
TRI 650 T120R & TR6 1969-70
#97-2293 Top Lug
TRIDENT/BSA (A75) 750 1969-70



FORK TUBES, SPRINGS, LEGS, MISC. PARTS

PART NO. DESCRIPTION and APPLICATION

- #97-1889 FORK STANCHION TUBE, TRI 500/650 TWINS, 1963 - 1967
- #97-3904 FORK STANCHION TUBE, TRI 650/750, 1968 - 1970, 500 THRU 1974
- #97-4007 FORK STANCHION TUBE, TRI/BSA, 650/750, 1971 - 1972
- #97-4380 FORK STANCHION TUBE, TRI 750, DISC BRAKE MODELS
- #97-2636 FORK STANCHION TUBE, BSA THRU 1968
- #97-3906 FORK STANCHION TUBE, BSA 1969 - 1970
- #06-3423 FORK STANCHION TUBE, NORTON COMMANDO

- #97-1891 FRONT FORK SPRING, TRI TWINS THRU 1970, SOLO
- #97-1892 FRONT FORK SPRING, TRI TWINS THRU 1970, H/DUTY
- #97-4011 FRONT FORK SPRING, TRI/BSA TWINS 1971 ON
- #97-4215 FRONT FORK SPRING, TRI/BSA 3 CYL 1971 ON
- #97-2644 FRONT FORK SPRING, BSA, THRU 1970

PART NO. DESCRIPTION and APPLICATION

- #97-4342 FORK LEG, LOWER LH, TRI/BSA 650/750, 1971 - 1972
- #97-4343 FORK LEG, LOWER RH, TRI/BSA 650/750, 1971 - 1972
- #97-4344 FORK LEG, LOWER RH, TRI/BSA 250, TR5T 1971 ON

- #97-2101 FORK YOKE, TOP, TRI 500/650 TWINS THRU 1968
- #97-4397 FORK YOKE, TOP, TRI 750 TWINS 1973 - 1978
- #97-7081 FORK YOKE, TOP, TRI T140 1979 - 1981
- #97-7194 FORK YOKE, TOP, TRI T140 1982 ON
- #97-4541 FORK YOKE, TOP, TRI T160 3 CYL
- #97-3987 FORK YOKE, BOTTOM, BSA/TRI SINGLES 1971 - 1972

- #97-3875 STEERING DAMPER KNOB, BSA EARLY & TRI 3 CYL
- #97-4102 BOTTOM NUT, DAMPER, BSA/TRI 3 CYL, 1971 ON

- #97-3907 FRONT FORK ASSY, TRI TWINS 1969 - 1970



HEADLITE BRACKETS

- | PART NO. | DESCRIPTION and APPLICATION |
|-----------------|---|
| #97-4058 | HEADLITE BRACKET, LH TRI/BSA 650, 1971-1972, WIRE TYPE |
| #97-4060 | HEADLITE BRACKET, RH TRI/BSA 650, 1971-1972, WIRE TYPE |
| #97-4088 | HEADLITE BRACKET, LH TRI 650 TR6C, 1971-1972, WIRE TYPE |
| #97-4090 | HEADLITE BRACKET, RH TRI 650 TR6C, 1971-1972, WIRE TYPE |
| #97-4162 | HEADLITE BRACKET, LH TRI/BSA 3 CYL 1971-EAR 1973, WIRE TYPE |
| #97-4163 | HEADLITE BRACKET, RH TRI/BSA 3 CYL 1971-EAR 1973, WIRE TYPE |
| #60-2630 | GROMMET, FOR WIRE TYPE HEADLITE BRACKET, 1971-1972 |
| | |
| #97-1887 | HEADLITE BRACKET, RH TRI 500/650 UNIT TWINS, THRU 1967 |
| #97-1888 | HEADLITE BRACKET, LH TRI 500/650 UNIT TWINS, THRU 1967 |
| | |
| #97-2161 | HEADLITE BRACKET, LH TRI 500/650 TWINS, 1968-1970 |
| #97-2162 | HEADLITE BRACKET, RH TRI 500/650 TWINS, 1968-1970 |
| | |
| #97-4121 | HEADLITE BRACKET, LH TRI 500/750, 1973-1978 |
| #97-4203 | HEADLITE BRACKET, RH TRI 500/750, 1973 ON |
| #97-4564 | HEADLITE BRACKET, LH TRI T140, 1979 ON |
| | |
| #97-2208 | RUBBER PAD, HEADLITE BRACKET, TRI, 1973 ON |



HEADLITE BRACKET SETS

- | PART NO. | DESCRIPTION and APPLICATION |
|-----------------|--|
| #JP51000 | HEADLITE BRACKET SET, CHROME UNIVERSAL, PAIR |



HANDLEBAR MOUNTING HARDWARE

- | PART NO. | DESCRIPTION and APPLICATION |
|-----------------|--|
| #97-2291 | HANDLEBAR EYEBOLT, ("P" CLAMP) TRI/BSA |
| #97-1425 | HANDLEBAR MOUNTING SHIM FOR "P" CLAMP |
| #97-1580 | RUBBER WASHER, HANDLEBAR MOUNT, TRI/BSA |
| | |
| #97-1581 | SPACER, HANDLEBAR MOUNT WASHER |
| #97-2221 | CUP WASHER, HANDLEBAR MOUNT |
| #97-1529 | HEMISPHERICAL WASHER, HANDLEBAR MOUNT |
| #97-1527 | BONDED RUBBER "SILENTBLOC" BUSH, HANDLEBAR MOUNT |



HEADLAMPS, RIMS, SHELLS, MISC.

PART NO.	DESCRIPTION and APPLICATION
#99-9968	HEADLAMP SHELL, TRI TWINS THRU 1966
#99-9969	HEADLAMP SHELL, TRI TWINS 1967 - 1970
#99-7039	HEADLAMP SHELL, TRI 500/750, 1973 - 1978
#99-7098	HEADLAMP SHELL, TRI T140 1979 ON
#54524099	HEADLAMP SHELL, 1969 - 1970 TRI/BSA, 3 CYL
#54524048	RUBBER COVER, FLAT BACK H/LITE, 1971 - 1972
#59892	HEADLAMP ASSY, 3 CYL MOD, 1969 - 1970, FLAT BACK
#JP31000	QUARTZ HALOGEN HEADLAMP CONVERSION, 7" DIA
#JP31000B	AS ABOVE, COMPLETE WITH #472P, H4 QUARTZ BULB
#553248J	HEADLAMP RIM, 7" DIA, Economy Replacement

NOTE: LUCAS ELECTRICS & AMAL CARBURETTERS ARE LISTED IN SEPARATE SECTIONS IN THE BACK OF THE PRICE SHEET.



BULBS

PART NO.	DESCRIPTION and APPLICATION
#472P	H4 QUARTZ BULB, 12 VOLT HALOGEN, 55/60 WATT
#410J	HEADLAMP BULB, 12 VOLT, 45/40W, Economy Replacement
#446J	HEADLAMP BULB, 12 VOLT, 50/40W, Economy Replacement
#312	HEADLAMP BULB, 6 VOLT
#380J	TAIL LIGHT BULB, 12 VOLT, Economy Replacement
#382J	SIGNAL LIGHT BULB, 12 VOLT, Economy Replacement
#384	TAIL LIGHT BULB, 6 VOLT
#989	PARKING LIGHT BULB, 12 VOLT, 6 WATT, BAYONET
#989J	PARKING LIGHT BULB, Economy Replacement
#951	PARKING LIGHT BULB, 6 VOLT BAYONET
#643	INDICATOR BULB, 12 VOLT, 3 WATT, BAYONET
#643J	INDICATOR BULB, Economy Replacement
#504	INDICATOR BULB, 12 VOLT, ALL GLASS
#987	INDICATOR BULB, 12 VOLT, SCREW TYPE
#281	MINI INDICATOR BULB, 12 VOLT
#281J	MINI INDICATOR BULB, Economy Replacement



LUCAS - LIGHTING

- A) #60513 Lamp Unit Assembly (7" Diameter)**
For 1973 and later with three indicator lights and headlight switch. Uses #410 Bulb
- B) #54522680 Light Unit (7" Diameter)**
For Norton and Triumph 750's 1978 on
Uses #410 Bulb
- C) #54517100 Light Unit (7" Diameter)**
For Most TRI/BSA's
Uses #370/446 Bulb
- D) #54584930 Lens for Tail Lamp**
TRI/Norton 1973 on
- E) #56606 Turn Signal Assembly**
Slotted stalk type
- F) #60600621 Lens for Turn Signal (Amber)**
Supersedes #54581638
- G) #534343 Rim**
For 5 3/4" Light Unit
- H) #553248 RIM**
For 7" Light Unit - All
- I) #57183 Reflector (Amber - Round)**
#57079 Reflector (Red - Round)
- J) #57160 Reflector (Amber - Rectangular)**
For Oil Cooler on Tridents
- K) #36403 Ammeter - Anti Vibration Design**
Fits Most Models
- L) #35048 Flasher Unit**
- M) #534296 Rim Clip**
Secures Rim to Headlamp Shell
- N) #144921 Screw**
For headlamp rim and tail light lens thru 1972
- O) #54938986R Fuse Holder**
With wire leads and fuse
- P) #188218R Fuse (35 Amp)**
- Q) #504665 Headlamp Clips**
Secures headlamp to rim
- R) #472-P Quartz Halogen H-4**
Headlamp Bulb (60/55W)
- S) #370 Headlamp Bulb**
(12 Volt 45/40 Watt)
#446 Headlamp Bulb
(12 Volt 50/40 Watt)
- T) #382 Blinker Bulb**
(12 Volt 21 Watt)
#380 Tail Light Bulb (12 Volt)
- U) #410 Headlamp Bulb**
(12 Volt 45/40 Watt)



TAIL LAMPS & LENSES

PART NO.	DESCRIPTION
#53454J	TAIL LIGHT ASSY, SMALL LUCAS STYLE, COPY
#53973J	TAIL LIGHT ASSY, BULLET STYLE, COPY
#56513	TAIL LIGHT ASSY, BOX STYLE, LUCAS
#56513J	TAIL LIGHT ASSY, BOX STYLE, COPY
#54576001J	LENSE, TAIL LIGHT, SMALL LUCAS STYLE, COPY
#54577109J	LENSE, TAIL LIGHT, BULLET STYLE, COPY
#54584930J	LENSE, TAIL LIGHT, BOX STYLE, COPY
#53454JWB	TAIL LIGHT ASSY, WITH BRACKET, DIECAST



SIGNAL LAMPS & LENSES

PART NO.	DESCRIPTION
#56606RL	SIGNAL LIGHT ASSY, LONG, W/SLOTTED STEM, LUCAS
#56606RS	SIGNAL LIGHT ASSY, SHORT, W/SLOTTED STEM, LUCAS
#56606JL	SIGNAL LIGHT ASSY, LONG, W/SLOTTED STEM, COPY
#56606JS	SIGNAL LIGHT ASSY, SHORT, W/SLOTTED STEM, COPY
#60600621R	LENSE, SIGNAL LIGHT, LUCAS
#60600621J	LENSE, SIGNAL LIGHT, COPY
#60-7448	SIGNAL LIGHT ASSY, FRONT & REAR, (HELLA) LATE TRI T140 (not illustrated)

NOTE: LUCAS ELECTRICS & AMAL CARBURETTORS ARE LISTED IN SEPARATE SECTIONS IN THE BACK OF THE PRICE SHEET.

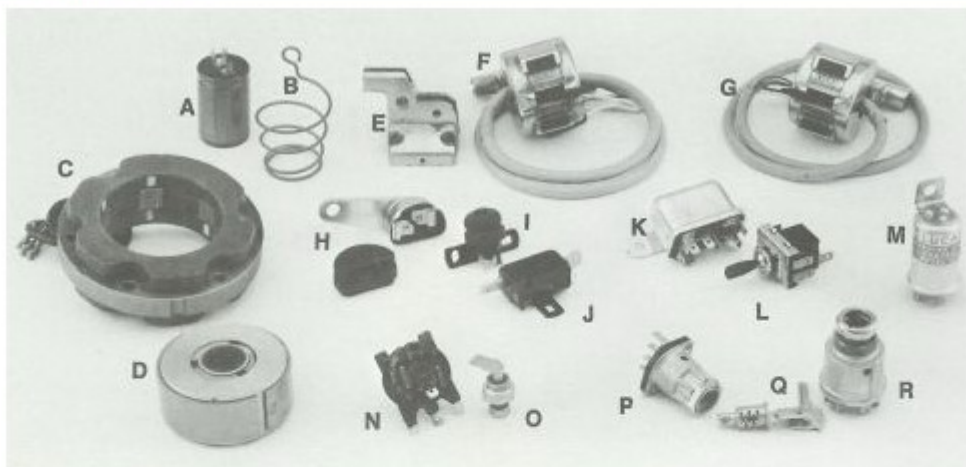

LUCAS - CHARGING, SWITCHES

- A) #54170009 Capacitor**
To be used instead of battery
- B) #83-4765 Capacitor Mounting Spring**
- C) #47204 Alternator Stator 3 Wire**
#47205 Alternator Stator 2 Wire
#47244 Alternator Stator 3 Wire
TRI 750 T140, Electric Start Models
#47252 Alternator Stator 3 Wire
TRI 750 T140, Kickstart Models, 1979 - 1980
- D) #54202299 Alternator Rotor**
Supersedes #54202275, #54212006,
#54213901, #54213902, #60600444,
#60600684
Most Applications
- E) #54343791 Lever Casting (LH)**
Handlebar Switch
- F) #39596 Handlebar Switch Unit (RH)**
For Direction Indicator, Ignition Cut-out
TRI/BSA, 1971 - 1972
Some TRI 1973 - 1974
- G) #39595 Handlebar Switch Unit (LH)**
For Horn, Headlamp Dip Switch and
Headlight Flasher Switch
TRI/BSA, 1971 - 1972
Some TRI 1973 - 1974
- H) #34448 Stop Lamp Switch**
BSA Lever Type - Twins thru 1970
- I) #34815J Stop Lamp Switch**
Button Type for Twins 1971 and on
Also fits most TRI/BSA Triples & Singles
- J) #54033234 Stop Lamp Switch**
Fits TRI Twins 500 thru 1974 and 650 thru 1970
- K) #33356 Start Relay**
Supersedes #33336
For TRI T160 - 3 Cylinder Electric Start
- L) #31788 Headlamp Toggle Switch (3 Position)**
Supersedes #35710
#34419 Headlamp Toggle Switch (3 Position)
(With Additional Terminals)
- M) #38706 Warning Light Simulator**
For most Nortons
- N) #49072 Rectifier (Positive Ground)**
For most applications
#83539 Rectifier (Negative Ground)
1979 & on for T140's
- O) #49345 Zener Diode (Positive Ground)**
Most applications
#49589 Zener Diode (Negative Ground)
1979 & on for T140's
- P) #30608 Ignition Switch Shell (2 Position Small)**
Supersedes #31899
- Q) #54335169R Lock & Keys**
Lucas Ignition Switches
- R) #39784 Ignition/Headlite Switch Shell (4 position)**
Supersedes #39565 & 35351
1971-72 Applications, also TRI T140, 1979 on



IGNITION PARTS

- | PART NO. | DESCRIPTION and APPLICATION |
|-----------------|--|
| A) #54415803 | CONTACT POINTS, SINGLES & TWINS 1963 - 1967 |
| #54415803R | CONTACT POINTS, Premium Replacement |
| #54415803J | CONTACT POINTS, Economy Replacement |
| B) #54419828J | CONTACT POINTS, 3 CYLINDER TRIDENT & BSA (A75) |
| C) #60600271 | CONTACT POINTS, SINGLES & TWINS 1972 ON |
| #60600271J | CONTACT POINTS, Economy Replacement |
| D) #54419827 | CONTACT POINTS, SINGLES & TWINS 1968 ON |
| #54419827J | CONTACT POINTS, Economy Replacement |
| E) #425377 | CONDENSER, USE WITH #54415803 POINTS, 1963 - 1967 |
| #425377J | CONDENSER, Economy Replacement |
| F) #54420128 | CONDENSER, 1968 & LATER, MOST APPLICATIONS |
| #54420128J | CONDENSER, Economy Replacement |
| #54441582J | CONDENSER, 1968 & LATER SINGLES, MOST APPLICATIONS |
| #54425657J | AUTO ADVANCE ASSY, TRI TWINS, 1968 ON |
| #45276R | 12 VOLT COIL, Premium Replacement |
| #45276J | 12 VOLT COIL, Economy Replacement |
| #45275R | 6 VOLT COIL, Premium Replacement |
| #45275J | 6 VOLT COIL, Economy Replacement |



ELECTRICAL, MISC.

- | PART NO. | DESCRIPTION and APPLICATION |
|-----------------|---|
| #60-3719 | OIL PRESSURE SWITCH, TRI/BSA TWINS & 3 CYL |
| #JP31010 | HORN, 12V, CHROME FACE UNIVERSAL |
| #PR90J | SPARK PLUG COVER, UNIVERSAL, LODGE TYPE |
| #49072J | RECTIFIER, JAPANESE Economy Replacement |
| #JP31030 | IGNITION SWITCH, UNIVERSAL |
| #JP31034 | HIGH-LOW/ HORN SWITCH, HANDLEBAR, UNIVERSAL |
| #82-9005 | BATTERY STRAP, TRI/BSA MOST MODELS |
| #82-8091 | BATTERY PAD, TRI/BSA 12V MOST MODELS |



NOTE: LUCAS ELECTRICS & AMAL CARBURETTORS ARE LISTED IN SEPARATE SECTIONS IN THE BACK OF THE PRICE SHEET.

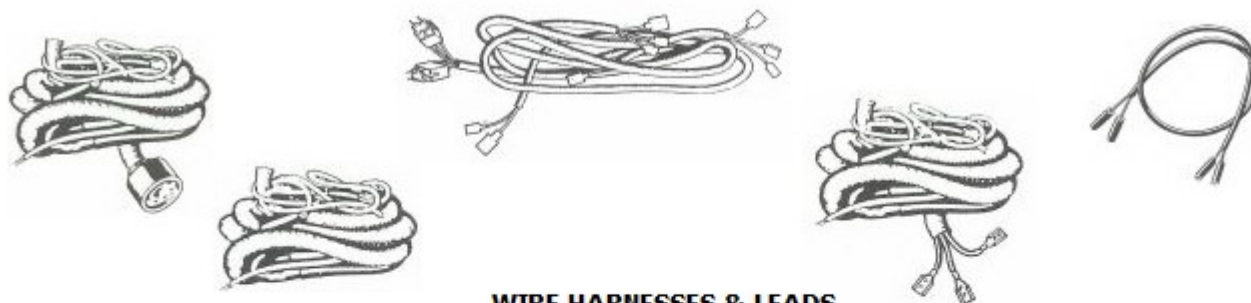

WIRE HARNESES & LEADS

PART NO.	DESCRIPTION	APPLICATION	PART NO.	DESCRIPTION	APPLICATION
#54936415R	MAIN HARNESS	TRI 650 TWINS, 1965	#54959638R	MAIN HARNESS	TRI/BSA 750, 3 CYL, 1971
#54938941R	MAIN HARNESS	TRI UNIT TWINS, 1966	#54959646	MAIN HARNESS	TRIDENT T150, 1971 - 1972
#54950449R	MAIN HARN ESS	TRI UNIT TWINS, 1967	#54961595R	MAIN HARNESS	TRIDENT T150, 1973 - 1975
#54953443R	MAIN HARNESS	TRI UNIT TWINS, 1968	#54962252R	MAIN HARNESS	TRIDENT T160, 1975
#54955256R	MAIN HARNESS	TRI UNIT TWINS, 1969 - 1970	#54960708	MAIN HARNESS	X75 HURRICANE
#54953440R	MAIN HARNESS	TRI TR6C/T100C, 1968	#54960707R	HEADLITE HARNESS	X75 HURRICANE
#54955719R	MAIN HARNESS	TRI TR6C/T100C, 1969 - 1970	#54955718R	MAIN HARNESS	BSA B44 1969, TRI 250 1968 - 1969
#54959628	MAIN HARNESS	TRI 500 UNIT TWINS, 1971 - 1974	#54934657R	MAIN HARNESS	BSA UNIT TWINS, 1965
#54959531	HEADLITE HARNESS	TRI 500 UNIT TWINS, 1971 - 1974	#54939347R	MAIN HARNESS	BSA UNIT TWINS, 1966
#54961594R	MAIN HARNESS	TRI 500, 1974 SERIES II	#54950625R	MAIN HARNESS	BSA UNIT TWINS, 1967
#54961591R	MAIN HARNESS	TRI 500 TR5T, 1973 - 1974	#54953385R	MAIN HARNESS	BSA UNIT TWINS, 1968
#54959629	MAIN HARNESS	TRI/BSA 650 TWINS, 1971 - 1972	#54955258R	MAIN HARNESS	BSA UNIT TWINS, 1969 - 1970
#54960711R	HEADLITE HARNESS	TRI/BSA 650 TWINS, 1971 - 1972	#54961586R	MAIN HARNESS	NORTON COMMANDO
#54961593R	MAIN HARNESS	TRI 750 TWINS, 1973 - 1975	#54960724R	HEADLITE HARNESS	NORTON COMMANDO
#54962258R	MAIN HARNESS	TRI 750 TWINS, 1976 - 1978	#54956251R	WIRE LEADS	CONTACT POINTS, TRI TWINS
#54965505R	MAIN HARNESS	TRI T140 1979 -	#54939169R	WIRE LEADS	CONTACT POINTS, TRI/BSA 3 CYL
#60-7465	MAIN HARNESS	TRI T140 1982 -	#838604R	WIRE LEADS	TAIL LITE, TWIN LEAD
			#54961700R	WIRE LEADS	TAIL LITE, TRI 750 TWINS 1973 - 1978
			#54941009R	WIRE LEADS	HIGH-LOW / HORN SWITCH

NOTE: LUCAS ELECTRICS & AMAL CARBURETTERS ARE LISTED IN SEPARATE SECTIONS IN THE BACK OF THE PRICE SHEET.

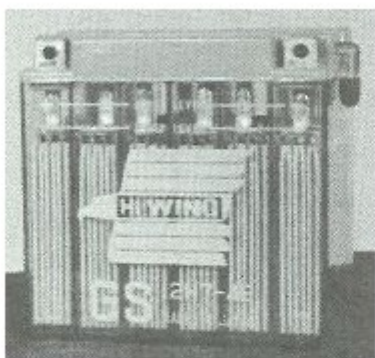

PREMIUM REPLACEMENT BATTERIES

PART NO.	DESCRIPTION and APPLICATION	DIMENSIONS (INCHES)		
		L	W	H
#BT12N7	12 VOLT BATTERY MOST TRI & BSA APPLICATIONS	5 1/4	3	5 1/4
#BT12N14	12 VOLT BATTERY TRI & NOR TWINS, ELEC START	5 1/4	3 1/2	6 1/2
#BT12N5	12 VOLT BATTERY COMPACT, CHOPPER/COMPETITION	4 3/4	2 3/8	5 1/8
#BT6N11	6 VOLT BATTERY MOST EARLY MODEL TRI & BSA	4 3/4	2 3/8	5 1/8

NOTE: ALL BATTERIES ARE SHIPPED DRY, WITHOUT ACID. THEY REQUIRE THE STANDARD ELECTROLYTE, WHICH IS COMMONLY AVAILABLE AT MOST GAS STATIONS, AUTO PART STORES, ETC.

PLEASE CONSULT THE PRICE SHEET FOR ADDITIONAL BATTERY STYLES AVAILABLE.



ELECTRONIC VOLTAGE REGULATOR/RECTIFIER

PART NO. DESCRIPTION
 #TYM12V VOLT PACK 12V POSITIVE OR NEGATIVE GROUND
 DESIGNED TO REPLACE BOTH THE ZENER DIODE AND RECTIFIER, ON PRE 1979 ALTERNATOR SYSTEMS. PRODUCES MAXIMUM OUTPUT.

CAN BE USED WITH:
 #54170009 CAPACITOR AND
 #83-4765 CAPACITOR MOUNTING SPRING
 TO REPLACE BATTERY AS WELL.



SPEEDO & TACH CABLES

PART NO.	DESCRIPTION and LENGTH
#JP41233	CABLE, SPEEDO TYPE, 2' 9" (33"), (BSA TWINS TACH)
#JP41241	CABLE, SPEEDOMETER, 3' 4 1/2", (EAR TRIUMPH)
#JP41244	CABLE, SPEEDOMETER, 3' 8" (44")
#JP41258	CABLE, SPEEDOMETER, 4' 10" (58")
#JP41263	CABLE, SPEEDOMETER, 5' 3" (63")
#JP41265	CABLE, SPEEDOMETER, 5' 5" (65")
#JP41266	CABLE, SPEEDOMETER, 5' 6" (66")
#JP41269	CABLE, SPEEDOMETER, 5' 9" (69")
#JP41271	CABLE, SPEEDOMETER, 5' 11" (71")
#JP41125	CABLE, TACHOMETER, 2' 1" (25")
#JP41126	CABLE, TACHOMETER, 2' 2 1/2" (26 1/2")
#JP41128	CABLE, TACHOMETER, 2' 4" (28")
#JP41130	CABLE, TACHOMETER, 2' 6" (30")
#JP41136	CABLE, TACHOMETER, 3' 0" (36")

SPEEDOMETER GEARBOX DRIVES

PART NO.	DESCRIPTION and APPLICATION
#BG5330287	SPEEDO GEARBOX, 2:1 RATIO, 3/4" BORE, RH DRIVE
#BG5330164	SPEEDO GEARBOX, 1.25:1 RATIO, 5/8" BORE, RH DRIVE
#BG5330168	SPEEDO GEARBOX, 1.25:1 RATIO, 3/4" BORE, RH DRIVE
#BG5330171	SPEEDO GEARBOX, 1.25:1 RATIO, 11/16" BORE, RH DRIVE
#60-7091	SPEEDO GEARBOX, VEGLIA, TRI T140 LH DRIVE, 1979 ON
#60-4099	TACHOMETER, TRI 500 TRST, 1973 - 1974

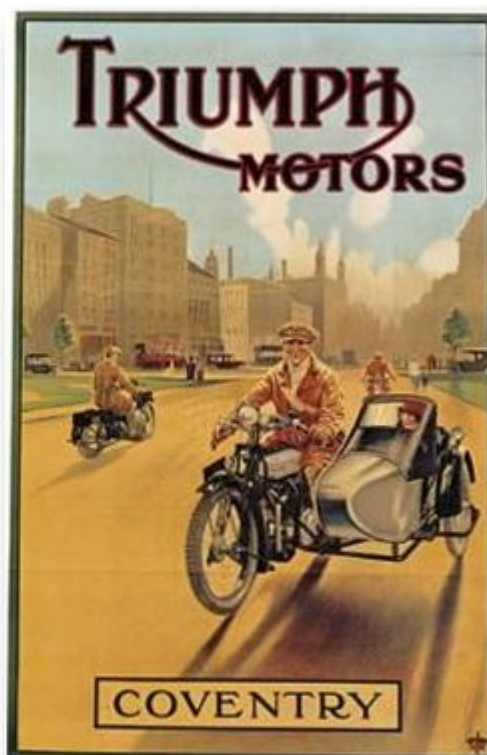



SERVICE TOOLS

PART NO. DESCRIPTION and APPLICATION

- #JP92101 AUTO ADVANCE EXTRACTOR, TRI/BSA/NOR
- #JP92102 CRANK TIMING PINION EXTRACTOR, TRI/NOR
- #JP92103 CAM GEAR EXTRACTOR KIT, TRI 500/650 TWINS
- #61-7019 ROCKER SHAFT, O RING TOOL, TRI 650/750

- #JP92105 TIMING DISC, W/ADAPTOR TRI #D605/8
- #JP92110 TDC TOOL, SPARK PLUG HOLE, WITH SCALE
- #JP92112 DEGREE WHEEL, CRANK TIMING, PLASTIC
- #61-7022 TDC TOOL, TRI TWINS, 1969 ON

- #JP92116 VALVE SPRING COMPRESSOR
- #JP92130 EXHAUST NUT SPANNER, NORTON
- #60-1050 SPARK PLUG SPANNER

- #JP92201 CLUTCH SPRING NUT TOOL, TRI/BSA
- #JP92202 CLUTCH HUB EXTRACTOR, TRI/BSA TWINS
- #JP92203 CLUTCH HUB EXTRACTOR, TRI/BSA 3 CYL
- #JP92204 CLUTCH HUB EXTRACTOR, BSA/TRI SINGLES
- #60-2108 PRIMARY CHAIN SCREWDRIVER, TRI
- #61-6070 CLUTCH HUB HOLDER, TRI/BSA 3 CYL
- #JP92231 CLUTCH SPRING EXTRACTOR, NORTON

PART NO. DESCRIPTION and APPLICATION

- #JP92503 FORK STANCHION REMOVAL/REFIT TOOL, W/ADAPTORS
- #60-0779 FORK CAP NUT SPANNER, TRI
- #JP92501 FORK SLEEVE NUT TOOL, TRI THRU 1970
- #JP92521 FORK SLEEVE NUT WRENCH, EARLY BSA

- #JP92502 PEG SPANNER, WHEEL BEARING RETAINER, TRI/BSA
- #5W6 SPOKE WRENCH, UNIVERSAL - 6 SIZES
- #99-3536 TYRE LEVER, STANDARD

- #JP92810 WRENCH SET, 7 PIECE COMBINATION, WHITWORTH
- #JP92812 WRENCH SET, 6 PIECE OPEN END, WHITWORTH

- #JP92830 SOCKET SET, 6 PIECE WHITWORTH
- #JP92832 SOCKET SET, 8 PIECE, WHITWORTH

- #JP92000 TOOL KIT, BRITISH, WITH POUCH
- #JP92001 TOOL POUCH ONLY

NOTE: PLEASE REFER TO THE "JP92—" SECTION IN THE PRICE SHEET FOR THE MOST CURRENT LISTING OF WORKSHOP TOOLS. ADDITIONAL TOOLS ARE LISTED IN THE "60" & "61" SECTIONS.



OWNERS MANUALS

PART NO.	DESCRIPTION and APPLICATION
#99-0895	OWNERS MANUAL, TRI 250 TR25W, 1970
#99-0873	OWNERS MANUAL, TRI 500 TWINS, 1967
#99-0893	OWNERS MANUAL, TRI 500 TWINS, 1970
#99-0978	OWNERS MANUAL, TRI 500 T100R, 1973
#99-0958	OWNERS MANUAL, TRI 500 TR5T, 1973
#99-0991	OWNERS MANUAL, TRI 500 TR5T, 1974
#99-0839	OWNERS MANUAL, TRI 650 TWINS, 1967
#99-0879	OWNERS MANUAL, TRI 650 TWINS, 1968
#99-0930	OWNERS MANUAL, TRI 650 TWINS, 1971
#99-0951	OWNERS MANUAL, TRI 650 TWINS, 1972
#99-0974	OWNERS MANUAL, TRI 750 TWINS, 1973
#00-4225	OWNERS MANUAL, TRI 750 TWINS, 1976
#99-7014	OWNERS MANUAL, TRI 750 T140V, 1978
#60-7284	OWNERS MANUAL, TRI 750 TWINS, 1980
#99-0938	OWNERS MANUAL, TRIDENT 750, T150, 1971
#99-0976	OWNERS MANUAL, TRIDENT 750, 1973, SERIES II
#00-4122	OWNERS MANUAL, BSA B44 VICTOR, 1966
#00-4144	OWNERS MANUAL, BSA B44 VICTOR/B25, 1969
#00-4116	OWNERS MANUAL, BSA A65/A50 TWINS, EARLY
#00-4184	OWNERS MANUAL, BSA A65 TWINS, 1971 - 1972
#00-4162	OWNERS MANUAL, BSA A75, 3 CYL, 1969 - 1970
#06-3852	OWNERS MANUAL, NORTON 750 & 850 COMMANDO
#06-6240	OWNERS MANUAL, NORTON 850, MK3

NOTE: PLEASE REFER TO THE "00", "60" & "99" SECTIONS OF THE PRICE SHEET FOR ADDITIONAL LISTINGS OF OWNERS MANUALS



**LAPEL BADGES, KEY FOBS
COFFEE MUGS**

PART NO.	DESCRIPTION
#JP90010TR	LAPEL BADGE, TRIUMPH
#JP90010B1	LAPEL BADGE, BSA STAR
#JP90010B2	LAPEL BADGE, BSA PILED ARMS
#JP90010NO	LAPEL BADGE, NORTON
#JP90010UJ	LAPEL BADGE, UNION JACK FLAG
#JP90020TR	KEY FOB, TRIUMPH
#JP90020BS	KEY FOB, BSA
#JP90020NO	KEY FOB, NORTON
#JP90030T1	COFFEE MUG, TRIUMPH, RED
#JP90030T2	COFFEE MUG, TRIUMPH, BLUE
#JP90030BS	COFFEE MUG, BSA
#JP90030NO	COFFEE MUG, NORTON



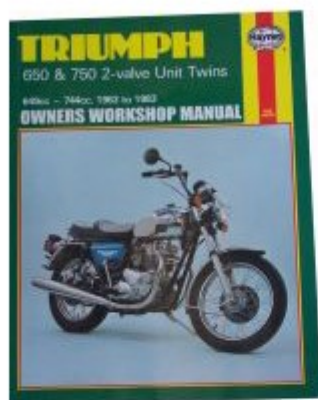

HAYNES SERVICE MANUALS

PART NO.	DESCRIPTION
#HM137	TRI 350/500, UNIT TWINS
#HM122	TRI 650/750, UNIT TWINS
#HM251	TRI 500/650, PRE-UNIT TWINS
#HM414	TRI TIGER CUB & TERRIER
#HM136	TRI/BSA 750 THREE CYL MODELS
#HM155	BSA A50/A65 UNIT TWINS
#HM121	BSA A7/A10 PRE-UNIT TWINS
#HM127	BSA 250-500, UNIT SINGLES
#HM125	NORTON TWINS, COMMANDO MODELS
#HM187	NORTON TWINS, PRE-COMMANDO
#HF257	BONNIE BOOK, HISTORY BY J.R. NELSON

NOTE: PLEASE REFER TO THE "JP90-" SECTION IN THE PRICE SHEET FOR ADDITIONAL BOOK AND ACCESSORY LISTINGS.

FACTORY SERVICE BOOKS

PART NO.	DESCRIPTION and APPLICATION	OEM #
#JP95028	FACTORY WORKSHOP MANUAL, TRI 250 SINGLES	99-0921
#JP95113	FACTORY WORKSHOP MANUAL, TRI 350/500, UNIT TWINS	99-0843/948
#JP95133	FACTORY WORKSHOP MANUAL, TRI 500 TR5T, 1973 - 74	99-0984
#JP95243	FACTORY WORKSHOP MANUAL, TRI 650, 1963 - 1970	99-0883/889
#JP95251	FACTORY WORKSHOP MANUAL, TRI 650, 1971 - 1972	99-0947
#JP95353	FACTORY WORKSHOP MANUAL, TRI 750 TWINS, THRU 1978	99-0983
#JP95362	FACTORY WORKSHOP MANUAL, TRI T140E, & ES, 1979 ON	99-7059
#JP95363S	FACTORY WORKSHOP MANUAL, SUPPLEMENT, TRI T140-TSS	
#JP95459	FACTORY WORKSHOP MANUAL, TRI T150 1969 - 1974	99-0963/0887
#JP95468	FACTORY WORKSHOP MANUAL, TRI T160 3 CYL, 1975	00-4225/W
#JP95619	FACTORY WORKSHOP MANUAL, BSA A65, 1969 - 1970	00-4177
#JP95621	FACTORY WORKSHOP MANUAL, BSA A65, 1971 - 1972	00-4189
#JP95719	FACTORY WORKSHOP MANUAL, BSA A75 3 CYL, 1969 ON	00-4191
#JP95810	FACTORY WORKSHOP MANUAL, NORTON 750/850	06-5146
#JP95815	FACTORY WORKSHOP MANUAL, NORTON 850 ELEC/START	00-4224

NOTE: PLEASE REFER TO THE "JP95-" SECTION IN THE PRICE SHEET FOR THE MOST CURRENT LISTING OF AVAILABLE FACTORY SERVICE BOOKS. ALSO, THE "JP94-" SECTION IN THE PRICE SHEET LISTS FACTORY PARTS BOOKS CURRENTLY AVAILABLE.



ALLEN HEAD CASE SCREW SETS

TRIUMPH

PART NO.	DESCRIPTION and APPLICATION
#JP93110	SCREW KIT, TRI 500 UNIT TWINS, CHAIN CASE, 1959-1968
#JP93111	SCREW KIT, TRI 500 UNIT TWINS, TIMING CASE, 1959-1968
#JP93112	SCREW KIT, TRI 500 UNIT TWINS, GEAR CASE, 1959-1968
#JP93113	SCREW KIT, TRI 500 UNIT TWINS, CHAIN CASE 1969 ON
#JP93114	SCREW KIT, TRI 500 UNIT TWINS, TIMING CASE, 1969 ON
#JP93115	SCREW KIT, TRI 500 UNIT TWINS, GEAR CASE, 1969 ON
#JP93122	SCREW KIT, TRI 650 UNIT TWINS, CHAIN CASE, 1963-1968
#JP93123	SCREW KIT, TRI 650 UNIT TWINS, TIMING CASE, 1963-1968
#JP93124	SCREW KIT, TRI 650 UNIT TWINS, GEAR CASE, 1963-1968
#JP93125	SCREW KIT, TRI 650/750 UNIT TWINS, CHAIN CASE, 1969 ON
#JP93126	SCREW KIT, TRI 650/750 UNIT TWINS, TIMING CASE, 1969 ON
#JP93127	SCREW KIT, TRI 650/750 UNIT TWINS, GEAR CASE, 1969 ON
#JP93140	SCREW KIT, TRI 750 TWIN, ROCKER CAPS
#JP93151	SCREW KIT, TRIDENT, T150, CHAIN CASE
#JP93161	SCREW KIT, TRIDENT, T160, CHAIN CASE
#JP93152	SCREW KIT, TRIDENT, T150/160, TIMING CASE
#JP93153	SCREW KIT, TRIDENT, T150, GEAR CASE
#JP93163	SCREW KIT, TRIDENT, T160, GEAR CASE

BSA

PART NO.	DESCRIPTION and APPLICATION
#JP93210	SCREW KIT, BSA/TRI SINGLES, CHAIN CASE, 1969 ON
#JP93211	SCREW KIT, BSA/TRI SINGLES, TIMING CASE, 1969 ON
#JP93225	SCREW KIT, BSA A65/A50 TWINS, CHAIN CASE, 1963-1968
#JP93226	SCREW KIT, BSA A65/A50 TWINS, TIMING CASE, 1963-1968
#JP93230	SCREW KIT, BSA A65/A50 TWINS, CHAIN CASE, 1969 ON
#JP93231	SCREW KIT, BSA A65/A50 TWINS, TIMING CASE, 1969 ON
#JP93253	SCREW KIT, BSA ROCKET 3, CHAIN CASE, 1969 ON
#JP93254	SCREW KIT, BSA ROCKET 3, TIMING CASE, 1969 ON
#JP93255	SCREW KIT, BSA ROCKET 3, GEAR CASE, 1969 ON

NORTON

#JP93310	SCREW KIT, NORTON TWINS, GEAR CASE
#JP93311	SCREW KIT, NORTON TWINS, TIMING CASE
#JP93314	SCREW KIT, NORTON 850 ELEC START, CHAIN CASE

BUSINESS POLICY

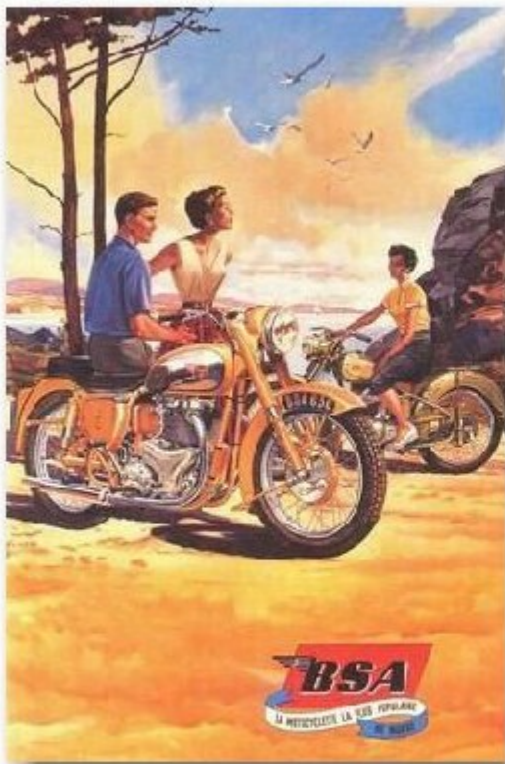

TERMS

- We accept MasterCard, Visa, Discover, and American Express credit cards.~We also accept COD, money orders and bank checks.
- Money orders in US dollars only.
- Please note, we reserve the right to hold orders on personal checks for up to three weeks allowing time for your check to clear the bank.
- We only ship COD via United Parcel Service.~They no longer accept cash. A money order or bank check is required.~Please note:~the COD fee is an additional \$9.00.

SHIPPING

Orders are usually processed within 24 hours of receipt.~Shipments are usually made via United Parcel Service or United States Postal Service.

FREIGHT ALLOWANCE

Freight costs are subject to change without notice due to fuel surcharges that may apply. There may also be freight increases from the shipper in the future.

Freight costs:	Order value	Freight charges
	.01 - 19.99	\$ 8.00
	20.00 - 74.99	\$10.00
	75.00 - 99.99	\$12.00
	Orders over \$300.00	Free shipping

This is ground shipping in the continental 48 states. Oversized packages, additional handling packages and hazardous packages do not qualify for free freight. Examples are: frames, motors, tires, etc:

ORDERS/RETURNS

- Orders of \$25.00 or less are subject to a \$7.00 service charge. No returns without authorization. No returns on electrical parts.
- When parts are returned to us for exchange, and the fault is ours, they will be exchanged no charge.
- Where the fault is not ours, the returns are subject to a 20% restocking/handling fee.
- Parts must be returned to us in good saleable condition before credit is issued.
- Shortages, returned parts or adjustments must be made within 20 days.

PRICES

All prices are subject to change without notice.

KLEMPFS BRITISH PARTS

61589 210 AVE. - DODGE CENTER, MINNESOTA 55927

507-374-2222